

# 1321 Power Conditioning Products

Bulletin Numbers 1321-3R Series D, 1321-3RA Series D, 1321-3RB Series D, 1321-RWR Series B, 1321-3TH Series A, 1321-3TW Series A, 1321-Mxxx Series A, 1321-DC Series A and B



Don't Ignore the Cost of Power Line Disturbance

| Topic  | Page |
|--|------|
| Summary of Changes                                     | 3    |
| Product Overview                                       | 3    |
| 1321-3R, 1321-3RA, and 1321-3RB Series D Line Reactors | 5    |
| 1321 Reflective Wave Reduction (RWR) Series B Devices  | 13   |
| 1321-3TH/3TW Series Three-Phase Isolation Transformers | 18   |
| 1321-Mxxx Common Mode Chokes                           | 23   |
| 1321-DC DC Link Chokes                                 | 27   |
| Additional Resources                                   | 31   |



For information on Bulletin Numbers 1321-3R\* Series A, B, C; and 1321-RWR Series A and 1321-RWR see Power Conditioning Products, publication [1321-TD002](#).

## Important User Information

Read this document and the documents listed in the additional resources section about installation, configuration, and operation of this equipment before you install, configure, operate, or maintain this product. Users are required to familiarize themselves with installation and wiring instructions in addition to requirements of all applicable codes, laws, and standards.

Activities including installation, adjustments, putting into service, use, assembly, disassembly, and maintenance are required to be carried out by suitably trained personnel in accordance with applicable code of practice.

If this equipment is used in a manner not specified by the manufacturer, the protection provided by the equipment may be impaired.

In no event will Rockwell Automation, Inc. be responsible or liable for indirect or consequential damages resulting from the use or application of this equipment.

The examples and diagrams in this manual are included solely for illustrative purposes. Because of the many variables and requirements associated with any particular installation, Rockwell Automation, Inc. cannot assume responsibility or liability for actual use based on the examples and diagrams.

No patent liability is assumed by Rockwell Automation, Inc. with respect to use of information, circuits, equipment, or software described in this manual.

Reproduction of the contents of this manual, in whole or in part, without written permission of Rockwell Automation, Inc., is prohibited.

Throughout this manual, when necessary, we use notes to make you aware of safety considerations.



**WARNING:** Identifies information about practices or circumstances that can cause an explosion in a hazardous environment, which may lead to personal injury or death, property damage, or economic loss.



**ATTENTION:** Identifies information about practices or circumstances that can lead to personal injury or death, property damage, or economic loss. Attentions help you identify a hazard, avoid a hazard, and recognize the consequence.

**IMPORTANT** Identifies information that is critical for successful application and understanding of the product.

These labels may also be on or inside the equipment to provide specific precautions.



**SHOCK HAZARD:** Labels may be on or inside the equipment, for example, a drive or motor, to alert people that dangerous voltage may be present.



**BURN HAZARD:** Labels may be on or inside the equipment, for example, a drive or motor, to alert people that surfaces may reach dangerous temperatures.



**ARC FLASH HAZARD:** Labels may be on or inside the equipment, for example, a motor control center, to alert people to potential Arc Flash. Arc Flash will cause severe injury or death. Wear proper Personal Protective Equipment (PPE). Follow ALL Regulatory requirements for safe work practices and for Personal Protective Equipment (PPE).

The following icon may appear in the text of this document.



Identifies information that is useful and can help to make a process easier to do or easier to understand.

## Summary of Changes

This publication contains the following new or updated information. This list includes substantive updates only and is not intended to reflect all changes.

| Topic   | Page   |
|---|--------|
| Removed 1321-3R Series A, B, C, 1321-3RA Series A, B, C, 1321-3RB Series A, B, C, and 1321-RWR Series A | 5...18 |
| Added 1321-3R Series D, 1321-3RA Series D, 1321-3RB Series D, and 1321-RWR Series B                     | 5...18 |



## Product Overview

Allen-Bradley reactors help keep equipment running longer by absorbing many of the power line disturbances that can shut down your drive. Allen-Bradley isolation transformers can provide both voltage change and isolation for your variable speed drive. These designs are harmonic compensated and insulated gate bi-polar transistor (IGBT) protected to help assure optimum performance in the presence of harmonics.

**IMPORTANT** This publication covers several series of products. Verify your series letter before you begin.

### Example Product Labels with Product Series Location

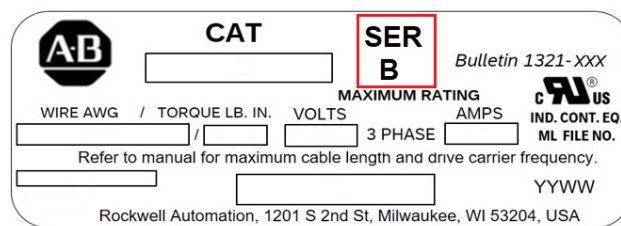
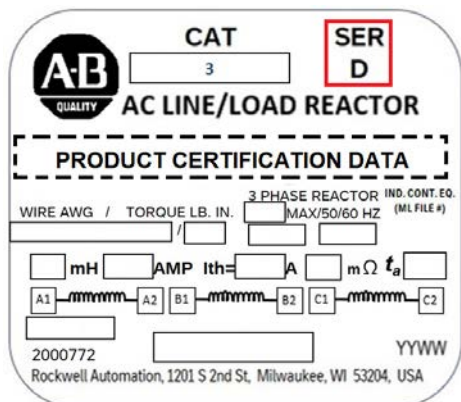

**PRODUCT ID LABEL RWR**

## Storage Guidelines

1321 Line Reactor products that are not installed and energized immediately should follow the storage guidelines. Following these guidelines will help reduce the appearance of oxidation from forming on the laminate surface and edges.

- Do not remove the protective packaging.
- Do not store the product outdoors or in an unprotected area.
- Do not store the product in an area where it is exposed to a corrosive atmosphere.
- Do not store the product where condensation could occur.
- Store the product in a climate-controlled building with adequate air circulation.
- Store the product in a clean, dust free, and dry atmosphere.
- Maintain a relative humidity level of less than 60% non-condensing.
- Limit rate of relative humidity change to less than 10% per hour.
- Store products on a vapor barrier membrane to help prevent water vapor migration.



**ATTENTION:** The presence of oxidation does not indicate performance issues.

## Mounting Clearance

The figure that follows shows the required mounting clearance. The ventilation clearance on open line reactors must have a minimum of 31.75 mm (1.25 in.) from all surfaces, such as walls and other equipment.

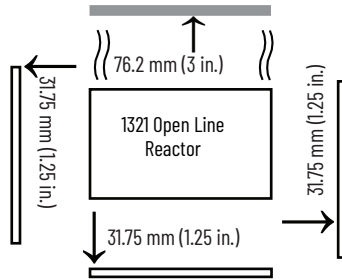

For the enclosed version of the line reactor, the ventilation clearance must have a minimum of 101.6 mm (4 in.) from all surfaces, such as walls and other equipment. The figure that follows shows the mounting clearances.

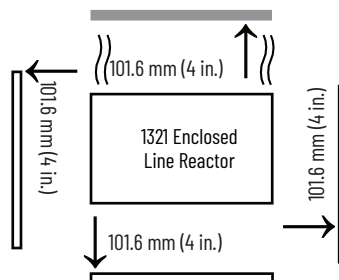

## Noise and Vibration

Reactors that are installed in more confining electrical rooms, when connected to the load, will exhibit higher (than standard) sound levels. Reactors will exhibit higher than normal sound levels if installed on suspended floors that may resonate. Reactors installed in close proximity to each other can also experience a resonant frequency between them that will result in higher than normal sound levels.



**ATTENTION:** Sound levels for reactors can vary, follow local codes and standards for hearing protection needs.

# 1321-3R, 1321-3RA, and 1321-3RB Series D Line Reactors

## Applying Allen-Bradley Line Reactors

### At the Input of the Drive

At the input of a drive, a line reactor helps protect against surges or spikes on the incoming power lines and help reduce harmonic distortion.

- Eliminate spurious tripping
- Extend semiconductor life
- Reduce harmonic distortion
- Improve true power factor
- Reduce voltage notching
- Meet IEEE-519 or EN-61800

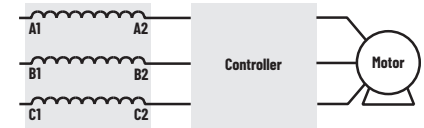

### At the Output of the Drive

In long motor lead applications, Allen-Bradley load reactors that are located between the drive and motor help reduce  $dv/dt$  and motor terminal peak voltages. The use of a load reactor also helps protect the drive from surge currents that are caused by rapid changes in the load.

- Protect motors from long lead effects
- Reduce output voltage  $dv/dt$
- Extend semiconductor life
- Reduce surge currents
- Reduce motor temperature
- Reduce audible motor noise

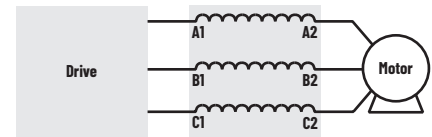

### With Multiple Drives

Multiple drives on a common power line should each have their own line reactor. Individual line reactors provide filtering between each drive to help reduce any crosstalk while providing optimum surge protection for each drive.

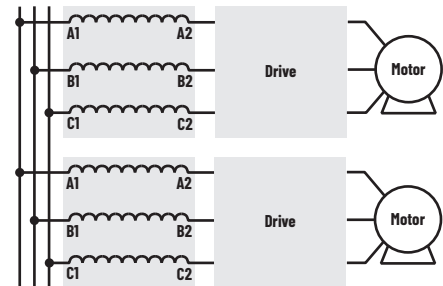

### With Multiple Motors

When multiple motors are controlled by one drive, a line reactor can typically be used between the drive and all of the motors. Size the line reactor based on the total motor/load horsepower.

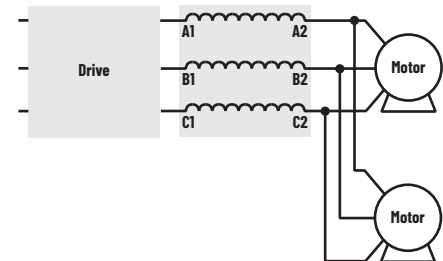

### With Single-Phase Input

A three-phase reactor can be used for single-phase applications by routing each of the two input power conductors to the outside two coils and leaving the center coil disconnected. The sum of the inductance of the two coils is the total inductance that is applied to the circuit. Contact Rockwell Automation Technical Support for assistance in specifying the proper reactor.

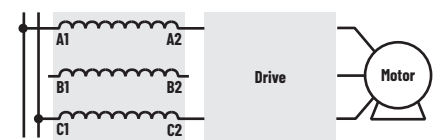

## Selecting the Correct Impedance Rating

### Why is the Correct Impedance Rating Important?

Selecting the correct impedance rating is critical for your job. An impedance value that is too low may not limit peak current. An impedance value that is too high may reduce input voltage. Allen-Bradley line reactors offer two impedance ratings.

### 3% Impedance Rated Reactors to Reduce Spurious Trips

Allen-Bradley line reactors that are rated at 3% are typically sufficient to absorb line spikes and motor current surges and will help prevent spurious tripping of drive and circuit breakers in most applications.

### 5% Impedance Rated Reactors to Reduce Harmonic Content

Allen-Bradley reactors that are rated at 5% are best for reducing harmonic current and frequencies. These line reactors help comply with IEEE-519 (not normally used as load reactors).

### Voltage Spike Protection

Voltage spikes on AC power lines can cause elevation of the DC bus voltage, which may cause the drive to trip on an overvoltage condition.

3% impedance reactors are effective at helping to protect drives against voltage spikes and spurious tripping. Allen-Bradley line reactors absorb these line spikes which help protect the drive from spurious tripping and damage.

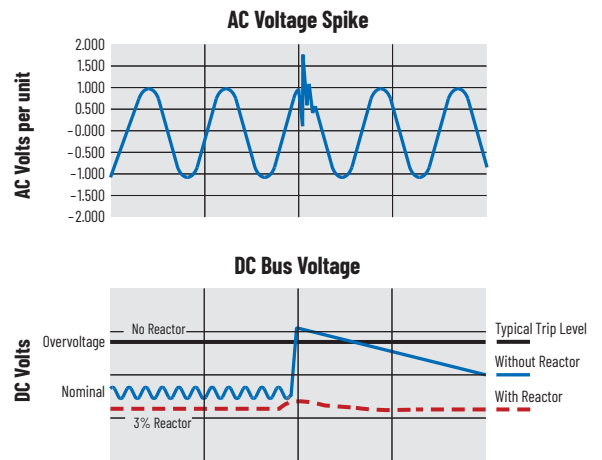

### Motor Protection

Allen-Bradley load reactors can help protect motors from high peak voltages.

For IGBT drive applications with long drive-to-motor lead lengths, Allen-Bradley load reactors can help protect against fast dv/dt rise times.

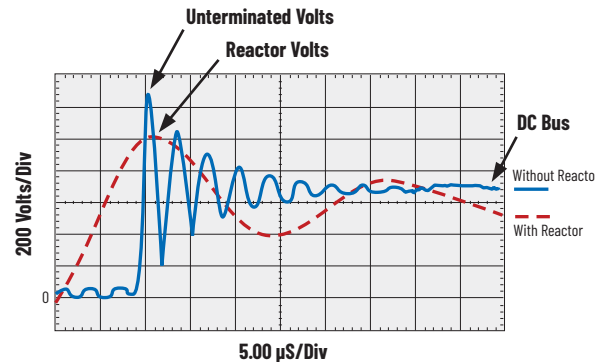

## Catalog Number Explanation

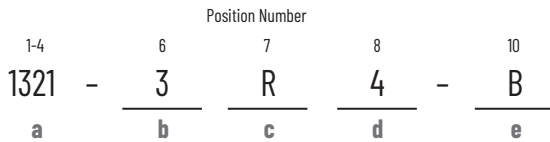

**a**

| Product |                      |
|---------|----------------------|
| Code    | Type                 |
| 1321    | 1321 Power Component |

**b**

| Phases |             |
|--------|-------------|
| Code   | Description |
| 3      | Three-Phase |

**c**

| Device                |                 |
|-----------------------|-----------------|
| Code                  | Description     |
| R, RB                 | Reactor, Open   |
| RA/RAB <sup>(1)</sup> | Reactor, NEMA 1 |

(1) RAB is only available in cabinet style 2 or 3.

**d**

| Fundamental Amps |      |
|------------------|------|
| Code             | Amps |
| 1                | 1    |
| 2                | 2    |
| 4                | 4    |
| 8                | 8    |
| 12               | 12   |
| 18               | 18   |
| 25               | 25   |
| 35               | 35   |
| 45               | 45   |
| 55               | 55   |
| 80               | 80   |
| 100              | 100  |
| 130              | 130  |
| 160              | 160  |
| 200              | 200  |
| 250              | 250  |
| 320              | 320  |
| 400              | 400  |
| 500              | 500  |
| 600              | 600  |
| 750              | 750  |
| 850              | 850  |
| 1000             | 1000 |

**e**

| Inductance Rating |   |
|-------------------|---|
| Code              | Description   |
| A                 | Each reactor current rating has four inductance ratings also available. See the IP00 dimension table. |
| B                 |   |
| C                 |   |
| D                 |   |

See [Typical Termination Types and Specifications on page 9](#) for dimensions.

## Common Specifications

| Specification  |   | Rating  |
|--|---|---|
| Material   | Enclosures  | IP11 (NEMA/UL Type 1) - Sheet steel in accordance with UL, NEMA requirements  |
|  |   | IP00 (Open) or IP20 (Open - with finger-safe terminals)   |
|  | Terminations <sup>(1)</sup>   | 1...45 A (fundamental) Ratings - Finger guard IP20 terminal block   |
| 55...200 A (fundamental) Ratings - Solid tin-plated aluminum box lugs                    |   |   |
| 250 A and above (fundamental) Ratings - Tin-plated aluminum-tab terminals <sup>(2)</sup> |   |   |
| Harmonic Compensation  | All line reactors are compensated for the additional currents and high frequencies that are caused by the presence of harmonics |   |
| General Protection   | Impedance   | 1.5%, 3%, or 5% based on the fundamental current ratings  |
|  | Overload Rating   | 200% of fundamental current for 30 minutes<br>300% of fundamental current for 1 minute  |
|  | dv/dt Protection  | Meets NEMA MG-1, part 31  |
| Electrical   | Maximum Rated Voltage   | 600V AC (units with terminal blocks)<br>690V AC (units with box lugs or tab terminals)  |
|  | Maximum Switching Freq.   | 20 kHz  |
|  | Fundamental Frequency   | Line/Load - 50/60 Hz  |
|  | Temperature Rise  | 135 °C (275 °F) average   |
|  | Dielectric Strength   | 4000 Volts rms (5656 volts peaks)   |
|  | Inductance Curve (Typical)  | 100% at 100% current<br>100% at 150% current ≤ 750 A, 100% at 125% current > 750 A<br>50% at 350% current (minimum) ≤ 750 A   |
|  | Inductance Tolerance  | ±10%  |
|  | Insulation System   | Class N: 200 °C (392 °F) < 80 A; Class R: 220 °C (428 °F) ≥ 80 A  |
| Environmental  | Impregnation  | High bond strength solventless epoxy, 220 °C, UL94HB recognized, or pre-catalyzed polyester   |
|  | Ambient Temperature   | 50 °C (122 °F) Open Style Reactor (maximum)<br>40 °C (104 °F) Enclosed Style Reactor (maximum)  |
|  | Altitude  | 1000 meters (3280 feet)   |
|  | Storage Temperature (all const.)  | -40...+70 °C (-40...+158 °F)  |
| Agency Approvals   | Humidity  | 5...95% noncondensing   |
|  | cULus<br>UL 508<br>CSA C22.2 Class N200C  | File E196302 Component Listed (1...2400 A)<br>File E196302 UL Listed NEMA Type 1 units (1...2400 A)<br>Note: Short Circuit rating not required under Exception No.1 of UL508A SB4.2.1 effective 4/25/06 |
|  | CE  | Certified to EN61558-2-20:2011 and EN61558-1:2005   |
|  | Morocco   | Compliance to NM EN 61800-5-1   |
|  | UKCA  | Compliance to EN 61800-3, EN 61800-5-1, EN IEC 63000  |

(1) For 250 A rating, see the [Termination](#) section of this document for additional information.

(2) For applications with reactors rated 250 A or greater with Tin-plated aluminum-tab terminals, cable-style connections are recommended. Hardware included on certain models.

## Termination

Reactors are supplied with either an integral-mounted terminal block, box lugs, or tin-plated aluminum-tabs which are front facing or side facing. See the tables that follow and the [Catalog Number Explanation](#) for specific information. The '3R' and '3RA' designations for the 1321 line reactors indicate the following: 3R = Open Enclosure Line Reactor and 3RA = NEMA 1 Enclosure Line Reactor. The dimensions and weights that are provided on the pages that follow are for estimating purposes only. Tab orientation may vary. Use specific hardware provided with product.

### Typical Termination Types and Specifications

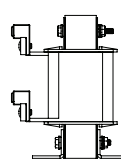
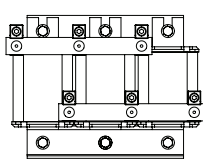
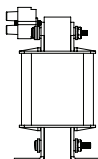
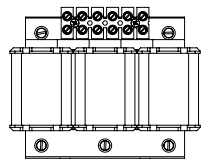
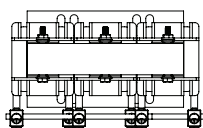

20, 65, or 85 A Terminal Blocks

Box Lugs

| Reactor Catalog Number              | Termination                  | Max/Min Wire Size                | Max Torque                  |
|-------------------------------------|------------------------------|----------------------------------|-----------------------------|
| <i>IP00 (Open) or IP20</i>          | <i>IP11 (NEMA/UL Type 1)</i> | <i>Type</i>                      | <i>mm<sup>2</sup> (AWG)</i> |
| <i>1321-3R1-A to 1321-3R4-D</i>     | <i>50 A Terminal Block</i>   | <i>0.5...10 (#20...#8 CU)</i>    | <i>0.8 (7.2)</i>            |
| <i>1321-3R8-A to 1321-3R35-B</i>    | <i>65 A Terminal Block</i>   | <i>0.5...16 (#20...#6 CU)</i>    | <i>1.47 (13.0)</i>          |
| <i>1321-3R35-C to 1321-3R45-C</i>   | <i>85 A Terminal Block</i>   | <i>0.75...25 (#18...#4 CU)</i>   | <i>2.26 (20.0)</i>          |
| <i>1321-3R55-A to 1321-3R130-C</i>  | <i>Box Lug</i>               | <i>16...70 (#6...#2/0 CU)</i>    | <i>13.56 (120.0)</i>        |
| <i>1321-3R160-A to 1321-3R200-C</i> | <i>Box Lug</i>               | <i>16...120 (#6...250 kcmil)</i> | <i>31.07 (275.0)</i>        |

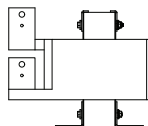
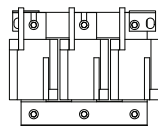
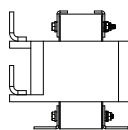
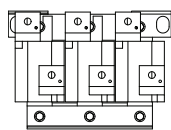
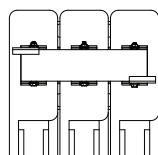
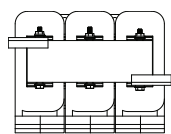

Front Facing Tin-plated Aluminum-tabs

Side Facing Tin-plated Aluminum-tabs

| Reactor Catalog Number                | Termination                                 | Contact Surface (H x W)          | Hole Diameter             | Max Torque           |
|---------------------------------------|---|----------------------------------|---------------------------|----------------------|
| <i>IP00 (Open) or IP20 (R, RB)</i>    | <i>IP11 (NEMA/UL Type 1) (RA, RAB)</i>      | <i>Type</i>                      | <i>mm (in.)</i>           | <i>mm (in.)</i>      |
| <i>1321-3RB250-A to 1321-3RB250-C</i> | <i>Front Facing Tin-plated Aluminum-tab</i> | <i>38.10 x 38.10 (1.5 x 1.5)</i> | <i>10.31 (0.406)</i>      | <i>20.34 (180.0)</i> |
| <i>1321-3RB320-A to 1321-3R500-A</i>  | <i>Front Facing Tin-plated Aluminum-tab</i> | <i>50.8 x 38.1 (2.0 x 1.5)</i>   | <i>10.31 (0.406)</i>      | <i>20.34 (180.0)</i> |
| <i>1321-3R500-B to 1321-3R750-C</i>   | <i>Side Facing Tin-plated Aluminum-tab</i>  | <i>101.6 x 63.5 (4.0 x 2.5)</i>  | <i>13.49 (0.531)</i>      | <i>50.84 (450.0)</i> |
| <i>1321-3R850-A to 1321-3R1000-C</i>  | <i>Front Facing Tin-plated Aluminum-tab</i> | <i>76.2 x 88.9 (3.0 x 3.5)</i>   | <i>(x4) 13.46 (0.531)</i> | <i>5.84 (450.0)</i>  |

For installation instructions, see 1321 Power Conditioning Products, publication [1321-PC001](#).

### Mounting Dimensions and Weights

**IMPORTANT** The dimensions and weights that are provided on the following pages are for estimating purposes only. Conduit entry locations for floor-mounted enclosures are the responsibility of the installer. Contact your Rockwell Automation sales office if certified drawings are required for planning and installation.

IP11 (NEMA/UL Type 1)

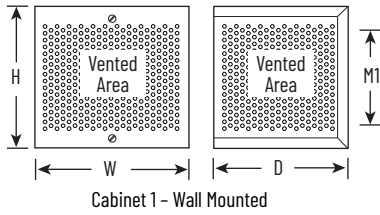

| Catalog Number              | Unit      | Dimensions in mm (in.) and Weights in kg (lb) |           |           |           |                       |
|-----------------------------|-----------|---|-----------|-----------|-----------|-----------------------|
|                             |           | H   | W         | D         | M1        | Weight (Cabinet Only) |
| 1321-3RA1-A to 1321-3RA18-B | Cabinet 1 | 203 (8.0)                                     | 211 (8.3) | 163 (6.4) | 152 (6.0) | 1.81 (4.0)            |

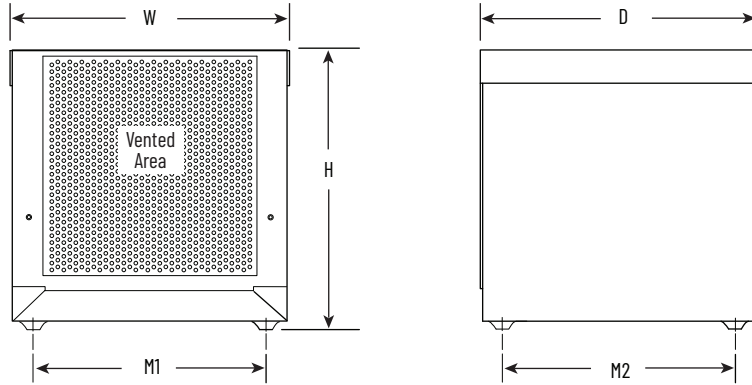

| Catalog Number                 | Unit      | Dimensions in mm (in.) and Weights in kg (lb) |            |            |            |            |                       |
|--------------------------------|-----------|---|------------|------------|------------|------------|-----------------------|
|                                |           | H   | W          | D          | Feet M1    | Feet M2    | Weight (Cabinet Only) |
| 1321-3RA18-C to 1321-3RAB250-A | Cabinet 2 | 340 (13.4)                                    | 333 (13.1) | 333 (13.1) | 279 (11.0) | 279 (11.0) | 6.4 (14.0)            |

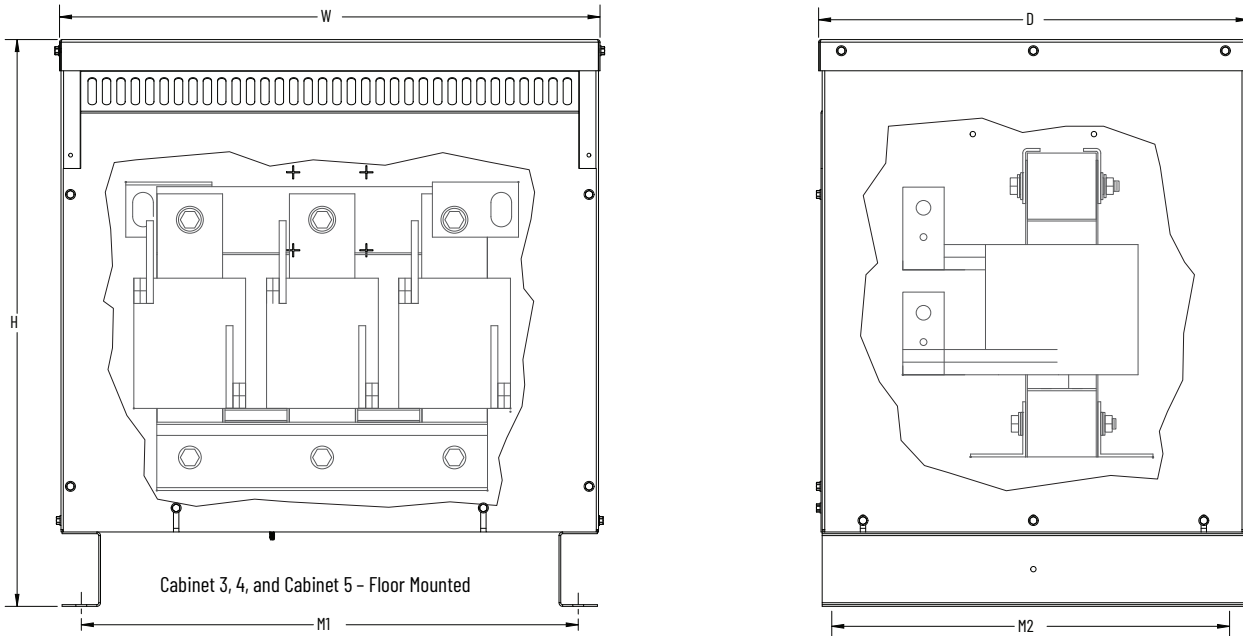

| Catalog Number                  | Unit      | Dimensions in mm (in.) and Weights in kg (lb) |            |            |            |            |                                      |
|---------------------------------|-----------|---|------------|------------|------------|------------|--------------------------------------|
|                                 |           | H   | W          | D          | Feet M1    | Feet M2    | Weight <sup>(1)</sup> (Cabinet Only) |
| 1321-3RAB250-B to 1321-3RA500-A | Cabinet 3 | 610 (24.0)                                    | 432 (17.0) | 432 (17.0) | 373 (14.7) | 396 (15.6) | 19.96 (44.0)                         |
| 1321-3RA500-B to 1321-3RA850-B  | Cabinet 4 | 749 (29.5)                                    | 716 (28.2) | 569 (22.4) | 658 (25.9) | 533 (21.0) | 35.8 (79.0)                          |
| 1321-3RA850-C to 1321-3RA1000-C | Cabinet 5 | 899 (35.4)                                    | 810 (31.9) | 683 (26.9) | 752 (29.6) | 648 (25.5) | 49 (108.0)                           |

(1) For total weight - add enclosure weight to specific reactor weight.

IP00/Open

Use the reactor outline shown to reference dimensions in the Sizing Guidelines. Dimensions A, B, and C show the width, height, and depth, respectively. Dimensions D, E, and F show the mounting dimensions. This diagram is for reference only - your actual product may differ in terminal location and type, as well as the number and type of mounting options. All dimensions are for reference only and should not be used for manufacturing purposes.

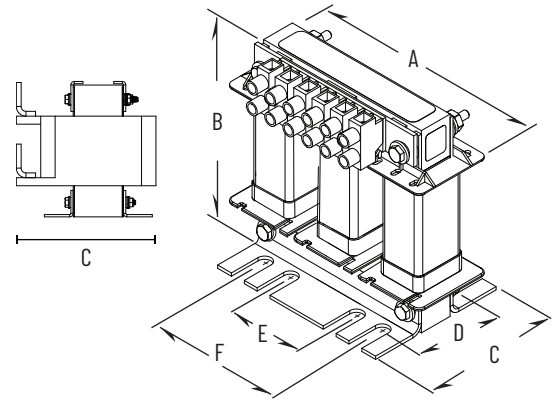

Sizing Guidelines

Fundamental amps are used for sizing the reactor to be equal to or slightly higher than the total motor FLA. Sizing reactors to drive ampere ratings alone may result in mis-sizing the reactor. 1321-3R1...3R35B are open slot and 1321-3R35C...3R1000C are closed slot.

Sizing Guidelines

| Catalog Number | Fundamental Amps | Inductance - mH<br>(Based on Fundamental Amps) | Watts Loss | Dimensions in mm (in.) and Weight in kg (lb) |             |             |           |          |            | Weight (apx.) |
|----------------|------------------|--|------------|--|-------------|-------------|-----------|----------|------------|---------------|
|                |                  |  |            | A  | B           | C (1)       | D (2) (3) | E        | F          |               |
| 1321-3R1-A     | 1                | 100  | 8          | 106.7 (4.2)                                  | 104.1 (4.1) | 76.2 (3.0)  | 46 (1.8)  | 37 (1.4) | 65 (2.6)   | 1.7 (3.7)     |
| 1321-3R1-B     |                  | 50   | 5          | 106.7 (4.2)                                  | 104.1 (4.1) | 66 (2.6)    | 36 (1.4)  | 37 (1.4) | 65 (2.6)   | 1.1 (2.5)     |
| 1321-3R1-C     |                  | 36   | 4          | 106.7 (4.2)                                  | 104.1 (4.1) | 66 (2.6)    | 36 (1.4)  | 37 (1.4) | 65 (2.6)   | 1.1 (2.5)     |
| 1321-3R1-D     |                  | 18   | 3          | 106.7 (4.2)                                  | 104.1 (4.1) | 66 (2.6)    | 36 (1.4)  | 37 (1.4) | 65 (2.6)   | 1.0 (2.3)     |
| 1321-3R2-A     | 2                | 12   | 9          | 106.7 (4.2)                                  | 104.1 (4.1) | 66 (2.6)    | 36 (1.4)  | 37 (1.4) | 65 (2.6)   | 1.0 (2.3)     |
| 1321-3R2-B     |                  | 20   | 19         | 106.7 (4.2)                                  | 104.1 (4.1) | 66 (2.6)    | 36 (1.4)  | 37 (1.4) | 65 (2.6)   | 1.1 (2.4)     |
| 1321-3R2-C     |                  | 32   | 18         | 106.7 (4.2)                                  | 104.1 (4.1) | 66 (2.6)    | 36 (1.4)  | 37 (1.4) | 65 (2.6)   | 1.3 (2.8)     |
| 1321-3R2-D     |                  | 6  | 6          | 106.7 (4.2)                                  | 104.1 (4.1) | 66 (2.6)    | 36 (1.4)  | 37 (1.4) | 65 (2.6)   | 1.1 (2.2)     |
| 1321-3R4-A     | 4                | 3  | 9          | 106.7 (4.2)                                  | 104.1 (4.1) | 66 (2.6)    | 36 (1.4)  | 37 (1.4) | 65 (2.6)   | 1.1 (2.2)     |
| 1321-3R4-B     |                  | 6.5  | 14         | 106.7 (4.2)                                  | 104.1 (4.1) | 66 (2.6)    | 36 (1.4)  | 37 (1.4) | 65 (2.6)   | 1.2 (2.7)     |
| 1321-3R4-C     |                  | 9  | 17         | 106.7 (4.2)                                  | 104.1 (4.1) | 76.2 (3.0)  | 46 (1.8)  | 37 (1.4) | 65 (2.6)   | 1.7 (3.8)     |
| 1321-3R4-D     |                  | 12   | 20         | 106.7 (4.2)                                  | 104.1 (4.1) | 83.8 (3.3)  | 52 (2.1)  | 37 (1.4) | 65 (2.6)   | 2.0 (4.5)     |
| 1321-3R8-A     | 8                | 1.5  | 10         | 149.9 (5.9)                                  | 124.5 (4.9) | 78.7 (3.1)  | 43 (1.7)  | 51 (2.0) | 76.2 (3.0) | 2.0 (4.5)     |
| 1321-3R8-B     |                  | 3  | 16         | 149.9 (5.9)                                  | 124.5 (4.9) | 78.7 (3.1)  | 43 (1.7)  | 51 (2.0) | 76.2 (3.0) | 2.2 (4.8)     |
| 1321-3R8-C     |                  | 5  | 21         | 149.9 (5.9)                                  | 124.5 (4.9) | 88.9 (3.5)  | 52 (2.1)  | 51 (2.0) | 76.2 (3.0) | 3.2 (6.9)     |
| 1321-3R8-D     |                  | 7.5  | 28         | 149.9 (5.9)                                  | 124.5 (4.9) | 88.9 (3.5)  | 52 (2.1)  | 51 (2.0) | 76.2 (3.0) | 3.2 (7.0)     |
| 1321-3R12-A    | 12               | 1.25   | 16         | 149.9 (5.9)                                  | 124.5 (4.9) | 78.7 (3.1)  | 43 (1.7)  | 51 (2.0) | 76.2 (3.0) | 2.2 (4.8)     |
| 1321-3R12-B    |                  | 2.5  | 23         | 149.9 (5.9)                                  | 124.5 (4.9) | 78.7 (3.1)  | 43 (1.7)  | 51 (2.0) | 76.2 (3.0) | 2.4 (5.3)     |
| 1321-3R12-C    |                  | 4.2  | 30         | 149.9 (5.9)                                  | 124.5 (4.9) | 94.0 (3.7)  | 59 (2.3)  | 51 (2.0) | 76.2 (3.0) | 3.7 (8.1)     |
| 1321-3R18-A    | 18               | 0.8  | 17         | 149.9 (5.9)                                  | 124.5 (4.9) | 78.7 (3.1)  | 43 (1.7)  | 51 (2.0) | 76.2 (3.0) | 2.3 (5.1)     |
| 1321-3R18-B    |                  | 1.5  | 25         | 149.9 (5.9)                                  | 124.5 (4.9) | 88.9 (3.5)  | 52 (2.1)  | 51 (2.0) | 76.2 (3.0) | 3.2 (7.1)     |
| 1321-3R18-C    |                  | 2.5  | 31         | 182.9 (7.2)                                  | 147.6 (5.8) | 96.5 (3.8)  | 57 (2.2)  | 76 (3.0) | —          | 5.2 (11.5)    |
| 1321-3R25-A    | 25               | 0.5  | 21         | 182.4 (7.2)                                  | 147.6 (5.8) | 91.4 (3.6)  | 51 (2.0)  | 76 (3.0) | —          | 4.0 (8.8)     |
| 1321-3R25-B    |                  | 1.2  | 39         | 182.4 (7.2)                                  | 147.6 (5.8) | 91.4 (3.6)  | 51 (2.0)  | 76 (3.0) | —          | 4.5 (10.0)    |
| 1321-3R25-C    |                  | 1.8  | 40         | 182.4 (7.2)                                  | 147.6 (5.8) | 114.3 (4.5) | 79 (2.8)  | 76 (3.0) | —          | 6.9 (15.2)    |
| 1321-3R35-A    | 35               | 0.4  | 25         | 182.4 (7.2)                                  | 147.6 (5.8) | 96.5 (3.8)  | 57 (2.2)  | 76 (3.0) | —          | 5.0 (11.1)    |
| 1321-3R35-B    |                  | 0.8  | 42         | 182.4 (7.2)                                  | 147.6 (5.8) | 96.5 (3.8)  | 57 (2.2)  | 76 (3.0) | —          | 5.1 (11.2)    |
| 1321-3R35-C    |                  | 1.2  | 44         | 227.8 (9.0)                                  | 182.9 (7.2) | 116.8 (4.6) | 83 (3.3)  | 76 (3.0) | 108 (4.3)  | 10.6 (23.3)   |
| 1321-3R45-A    | 45               | 0.3  | 29         | 227.8 (9.0)                                  | 182.9 (7.2) | 116.8 (4.6) | 83 (3.3)  | 76 (3.0) | 108 (4.3)  | 9.0 (19.8)    |
| 1321-3R45-B    |                  | 0.7  | 46         | 227.8 (9.0)                                  | 182.9 (7.2) | 116.8 (4.6) | 83 (3.3)  | 76 (3.0) | 108 (4.3)  | 9.9 (21.8)    |
| 1321-3R45-C    |                  | 1.2  | 63         | 227.8 (9.0)                                  | 182.9 (7.2) | 129.5 (5.1) | 96 (3.8)  | 76 (3.0) | 108 (4.3)  | 12.6 (27.8)   |

Sizing Guidelines (Continued)

| Catalog Number | Fundamental Amps | Inductance - mH<br>(Based on Fundamental Amps) | Watts Loss | Dimensions in mm (in.) and Weight in kg (lb) |              |                 |            |            |              |               |
|----------------|------------------|--|------------|--|--------------|-----------------|------------|------------|--------------|---------------|
|                |                  |  |            | A  | B            | C (1)           | D (2) (3)  | E          | F            | Weight (apx.) |
| 1321-3R55-A    | 55               | 0.25   | 32         | 227.8 (9.0)                                  | 174.0 (6.9)  | 116.8 (4.6) 5.4 | 83 (3.3)   | 76 (3.0)   | 108 (4.3)    | 8.9 (19.6)    |
| 1321-3R55-B    |                  | 0.5  | 50         | 227.8 (9.0)                                  | 174.0 (6.9)  | 116.8 (4.6) 5.4 | 83 (3.3)   | 76 (3.0)   | 108 (4.3)    | 9.5 (21.0)    |
| 1321-3R55-C    |                  | 0.85   | 61         | 227.8 (9.0)                                  | 174.0 (6.9)  | 129.5 (5.1) 5.9 | 96 (3.8)   | 76 (3.0)   | 108 (4.3)    | 12.6 (27.8)   |
| 1321-3R80-A    | 80               | 0.2  | 59         | 228.6 (9.0)                                  | 203.2 (8.0)  | 157.5 (6.2)     | 83 (3.3)   | 76 (3.0)   | 108 (4.3)    | 12.7 (28.0)   |
| 1321-3R80-B    |                  | 0.4  | 82         | 233.7 (9.2)                                  | 200.7 (7.9)  | 172.7 (6.8)     | 96 (3.8)   | 76 (3.0)   | 108 (4.3)    | 15 (33.0)     |
| 1321-3R80-C    |                  | 0.7  | 106        | 292.1 (11.5)                                 | 218.4 (8.6)  | 208.3 (8.2)     | 111 (4.4)  | 92 (3.63)  | 141.7 (5.6)  | 22.7 (50.0)   |
| 1321-3R100-A   | 100              | 0.15   | 59         | 228.6 (9.0)                                  | 200.7 (7.9)  | 165.1 (6.5)     | 83 (3.3)   | 76 (3.0)   | 108 (4.3)    | 13.2 (29.0)   |
| 1321-3R100-B   |                  | 0.3  | 94         | 238.8 (9.4)                                  | 200.7 (7.9)  | 175.3 (6.9)     | 96 (3.8)   | 76 (3.0)   | 108 (4.3)    | 15.9 (35.0)   |
| 1321-3R100-C   |                  | 0.45   | 108        | 292.1 (11.5)                                 | 218.4 (8.6)  | 195.6 (7.7)     | 111 (4.4)  | 92 (3.63)  | 141.7 (5.6)  | 24.5 (54.0)   |
| 1321-3R130-A   | 130              | 0.1  | 71         | 259.1 (10.2)                                 | 210.8 (8.3)  | 170.2 (6.7)     | 83 (3.3)   | 76 (3.0)   | 108 (4.3)    | 13.6 (30.0)   |
| 1321-3R130-B   |                  | 0.2  | 117        | 259.1 (10.2)                                 | 210.8 (8.3)  | 210.8 (8.3)     | 108 (4.3)  | 76 (3.0)   | 108 (4.3)    | 17.2 (38.0)   |
| 1321-3R130-C   |                  | 0.3  | 116        | 292.1 (11.5)                                 | 215.9 (8.5)  | 226.1 (8.9)     | 117 (4.6)  | 92 (3.63)  | 141.7 (5.6)  | 25.4 (56.0)   |
| 1321-3R160-A   | 160              | 0.075  | 71         | 259.1 (10.2)                                 | 200.7 (7.9)  | 190.5 (7.5)     | 108 (4.3)  | 76 (3.0)   | 108 (4.3)    | 20.0 (44.0)   |
| 1321-3R160-B   |                  | 0.15   | 112        | 289.6 (11.4)                                 | 218.4 (8.6)  | 218.4 (8.6)     | 98 (3.9)   | 92 (3.63)  | 141.7 (5.6)  | 20.4 (45.0)   |
| 1321-3R160-C   |                  | 0.23   | 131        | 289.6 (11.4)                                 | 218.4 (8.6)  | 228.6 (9.0)     | 123 (4.9)  | 92 (3.63)  | 141.7 (5.6)  | 29.5 (65.0)   |
| 1321-3R200-A   | 200              | 0.055  | 83         | 256.5 (10.1)                                 | 188.0 (7.4)  | 195.6 (7.7)     | 108 (4.3)  | 76 (3.0)   | 108 (4.3)    | 16.3 (36.0)   |
| 1321-3R200-B   |                  | 0.11   | 142        | 256.5 (10.1)                                 | 203.2 (8.0)  | 233.7 (9.2)     | 122 (4.8)  | 76 (3.0)   | 108 (4.3)    | 22.2 (49.0)   |
| 1321-3R200-C   |                  | 0.185  | 146        | 284.5 (11.2)                                 | 218.4 (8.6)  | 259.1 (10.2)    | 142 (5.6)  | 92 (3.63)  | 141.7 (5.6)  | 34.9 (77.0)   |
| 1321-3RB250-A  | 250              | 0.045  | 122        | 256.5 (10.1)                                 | 203.2 (8.0)  | 266.7 (10.5)    | 108 (4.3)  | 92 (3.63)  | 108 (4.3)    | 18.1 (40.0)   |
| 1321-3RB250-B  |                  | 0.09   | 116        | 284.5 (11.2)                                 | 231.1 (9.1)  | 241.3 (9.5)     | 124 (4.9)  | 92 (3.63)  | 141.7 (5.6)  | 29.5 (65.0)   |
| 1321-3RB250-C  |                  | 0.15   | 178        | 381.0 (15.0)                                 | 287.0 (11.3) | 251.5 (9.9)     | 155 (6.1)  | 117 (4.6)  | 182.89 (7.2) | 52.2 (115.0)  |
| 1321-3RB320-A  | 320              | 0.04   | 149        | 284.5 (11.2)                                 | 218.4 (8.6)  | 218.4 (8.6)     | 123 (4.9)  | 92.2 (3.6) | 141.7 (5.6)  | 27.7 (61.0)   |
| 1321-3RB320-B  |                  | 0.075  | 222        | 284.5 (11.2)                                 | 218.4 (8.6)  | 243.8 (9.6)     | 149 (5.9)  | 92.2 (3.6) | 141.7 (5.6)  | 37.2 (82.0)   |
| 1321-3RB320-C  |                  | 0.125  | 241        | 360.7 (14.2)                                 | 289.6 (11.4) | 299.7 (11.8)    | 181 (7.1)  | 117 (4.6)  | 182.9 (7.2)  | 57.6 (127.0)  |
| 1321-3RB400-A  | 400              | 0.03   | 146        | 284.5 (11.2)                                 | 231.1 (9.1)  | 259.1 (10.2)    | 136 (5.4)  | 92.2 (3.6) | 141.7 (5.6)  | 32.6 (72.0)   |
| 1321-3RB400-B  |                  | 0.06   | 203        | 355.6 (14.0)                                 | 289.6 (11.4) | 279.4 (11.0)    | 168 (6.6)  | 117 (4.6)  | 182.9 (7.2)  | 49.9 (110.0)  |
| 1321-3RB400-C  |                  | 0.105  | 285        | 360.7 (14.2)                                 | 289.6 (11.4) | 320.0 (12.6)    | 193 (7.6)  | 117 (4.6)  | 182.9 (7.2)  | 64.4 (142.0)  |
| 1321-3R500-A   | 500              | 0.025  | 158        | 284.5 (11.2)                                 | 231.1 (9.1)  | 297.2 (11.7)    | 136 (5.4)  | 92.2 (3.6) | 141.7 (5.6)  | 34.9 (77.0)   |
| 1321-3R500-B   |                  | 0.05   | 242        | 368.3 (14.5)                                 | 299.7 (11.8) | 355.6 (14.0)    | 181 (7.1)  | 117 (4.6)  | 182.9 (7.2)  | 57.6 (127.0)  |
| 1321-3R500-C   |                  | 0.085  | 308        | 368.3 (14.5)                                 | 299.7 (11.8) | 414.0 (16.3)    | 231 (9.1)  | 117 (4.6)  | 182.9 (7.2)  | 85.7 (189.0)  |
| 1321-3R600-A   | 600              | 0.02   | 222        | 368.3 (14.5)                                 | 299.7 (11.8) | 304.8 (12.0)    | 155 (6.1)  | 117 (4.6)  | 182.9 (7.2)  | 49.9 (110.0)  |
| 1321-3R600-B   |                  | 0.04   | 279        | 368.3 (14.5)                                 | 299.7 (11.8) | 348.0 (13.7)    | 193 (7.6)  | 117 (4.6)  | 182.9 (7.2)  | 66.7 (147.0)  |
| 1321-3R600-C   |                  | 0.065  | 355        | 368.3 (14.5)                                 | 299.7 (11.8) | 419.1 (16.5)    | 257 (10.1) | 117 (4.6)  | 182.9 (7.2)  | 99.4 (219.0)  |
| 1321-3R750-A   | 750              | 0.015  | 227        | 368.3 (14.5)                                 | 299.7 (11.8) | 345.4 (13.6)    | 168 (6.6)  | 117 (4.6)  | 182.9 (7.2)  | 54.4 (120.0)  |
| 1321-3R750-B   |                  | 0.029  | 327        | 373.4 (14.7)                                 | 365.8 (14.4) | 373.4 (14.7)    | 197 (7.8)  | 117 (4.6)  | 182.9 (7.2)  | 93.0 (205.0)  |
| 1321-3R750-C   |                  | 0.048  | 433        | 381.0 (15.0)                                 | 365.8 (14.4) | 391.2 (15.4)    | 223 (8.8)  | 117 (4.6)  | 182.9 (7.2)  | 111.6 (246.0) |
| 1321-3R850-A   | 850              | 0.015  | 293        | 365.8 (14.4)                                 | 365.8 (14.4) | 315.0 (12.4)    | 206 (8.1)  | 117 (4.6)  | 182.9 (7.2)  | 66.7 (147.0)  |
| 1321-3R850-B   |                  | 0.027  | 386        | 365.8 (14.4)                                 | 365.8 (14.4) | 327.7 (12.9)    | 219 (8.6)  | 117 (4.6)  | 182.9 (7.2)  | 78.9 (174.0)  |
| 1321-3R850-C   |                  | 0.042  | 386        | 365.8 (14.4)                                 | 365.8 (14.4) | 393.7 (15.5)    | 282 (11.1) | 117 (4.6)  | 182.9 (7.2)  | 118.9 (262.0) |
| 1321-3R1000-B  | 1000             | 0.022  | 507        | 375.9 (14.8)                                 | 373.4 (14.7) | 368.3 (14.5)    | 231 (9.1)  | 117 (4.6)  | 182.9 (7.2)  | 89.4 (197.0)  |
| 1321-3R1000-C  |                  | 0.038  | 480        | 375.9 (14.8)                                 | 373.4 (14.7) | 419.1 (16.5)    | 282 (11.1) | 117 (4.6)  | 182.9 (7.2)  | 121.6 (268.0) |

(1) Dimension C is measured at the widest point of the line reactor. This could be at the base or at the terminal depending on the catalog number. See [Typical Termination Types and Specifications on page 9](#) for examples of line reactor types.  
 (2) Removable lifting rings are supplied with the unit.  
 (3) For closed slot units, the center dimension is measured from the center of the slot. For open slots, the center dimension is measured from the inner most radii.

# 1321 Reflective Wave Reduction (RWR) Series B Devices

## Description of Reflected Wave Phenomenon

The inverter section of a drive does not produce sinusoidal voltage, but rather a series of voltage pulses created from the DC bus. These pulses travel down the motor cables to the motor and then reflected back to the drive. The reflection is dependent on the rise time of the drive output voltage, cable characteristics, cable length, and motor impedance. If the voltage reflection is combined with another subsequent pulse, peak voltages can be at a destructive level. An IGBT drive output may have reflected wave transient voltage stresses of up to twice (2 pu or per unit) the DC bus voltage between its own output wires. Multiple drive output wires in a single conduit or wire tray further increase output wire voltage stress between multi-drive output wires that are touching. Drive #1 may have a (+) 2 pu stress while drive #2 may simultaneously have a (-) 2 pu stress.

For more details, see the Wiring and Grounding Guidelines for Pulse Width Modulated (PWM) AC Drives, publication [DRIVES-IN001](#).

## Applying RWR Devices

### At the Output of the Drive

In long motor lead applications, an Allen-Bradley 1321 RWR located between the drive and motor helps to reduce dv/dt and motor terminal peak voltages. The use of an RWR device also helps protect the drive from surge currents that are caused by rapid changes in the load.

- Protect motors from long lead effects
- Reduce output voltage dv/dt
- Extend semiconductor life
- Reduce surge currents
- Reduce motor temperature
- Reduce audible motor noise

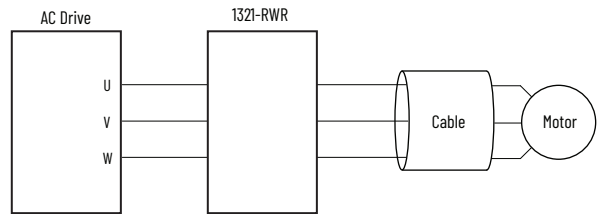

### Motor Protection

Allen-Bradley RWR devices can help protect motors from high peak voltages.

For IGBT drive applications with long drive-to-motor lead lengths, Allen-Bradley RWR devices can help protect against fast dv/dt rise times.

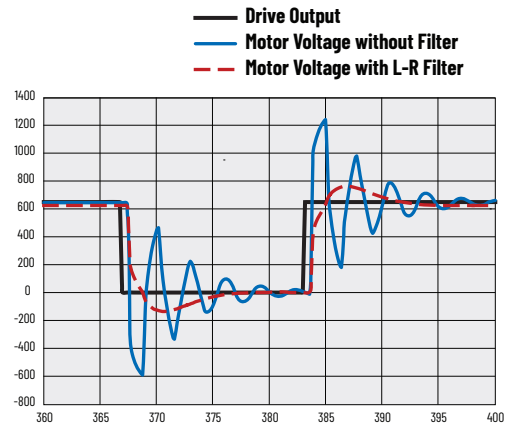

## Catalog Number Explanation

**IMPORTANT** 1321-RWR products replace existing 1204-RWR products. However, 1204-RWRC modules (RWR and Common Mode Choke assembly) are still available.

## Specifications

### Specifications

| Specification | Rating   |
|---------------|--|
| Enclosures    | IP00 (Open)  |
| Material      | 1...45 A (fundamental) Ratings - Finger guard IP20 terminal block                    |
|               | 55...320 A (fundamental) Ratings - Solid tin-plated aluminum box lugs                |
|               | 200...400 A (fundamental) Ratings - Tin-plated aluminum-tab terminals <sup>(1)</sup> |
|               | 401 A and above - Tin-plated aluminum-tab terminals <sup>(1)</sup>                   |

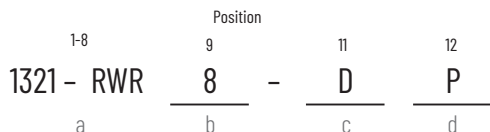

| a              |                                  |
|----------------|----------------------------------|
| Product        |                                  |
| Code           | Type                             |
| 1321-RWR       | Reflective Wave Reduction Device |
| c              |                                  |
| Voltage Rating |                                  |
| Code           | Voltage                          |
| D              | 400/480V AC                      |
| E              | 600V AC                          |
| d              |                                  |
| Enclosure      |                                  |
| Code           | Description                      |
| P              | Panel Mount                      |

| b1          |                  |
|-------------|------------------|
| Rating      |                  |
| 400-480V AC |                  |
| Code        | Fundamental Amps |
| 8           | 8                |
| 12          | 12               |
| 18          | 18               |
| 25          | 25               |
| 35          | 35               |
| 45          | 45               |
| 55          | 55               |
| 80          | 80               |
| 100         | 100              |
| 130         | 130              |
| 160         | 160              |
| 200         | 200              |
| 250         | 250              |
| 320         | 320              |

| b2      |                  |
|---------|------------------|
| Rating  |                  |
| 600V AC |                  |
| Code    | Fundamental Amps |
| 8       | 8                |
| 12      | 12               |
| 18      | 18               |
| 25      | 25               |
| 35      | 35               |
| 45      | 45               |
| 55      | 55               |
| 80      | 80               |
| 100     | 100              |
| 130     | 130              |
| 160     | 160              |
| 200     | 200              |
| 250     | 250              |

**Specifications (Continued)**

| Specification         | Rating  |
|-----------------------|---|
| Harmonic Compensation | All line reactors are compensated for the additional currents and high frequencies that are caused by the presence of harmonics |
| General Protection    | Impedance   |
|                       | Overload Rating   |
| IGBT Protection       | 16,000 Volts per microsecond dv/dt protection<br>20 kHz maximum switching frequency   |
| Electrical            | Maximum Rated Voltage   |
|                       | Maximum Switching Freq.   |
|                       | Temperature Rise  |
|                       | Dielectric Strength   |
|                       | Inductance Curve  |
|                       | Insulation System   |
| Environmental         | Impregnation  |
|                       | Ambient Temperature   |
|                       | U.L. Listed   |
|                       | CE  |
|                       | Storage Temperature (all const.)  |
| Humidity              |   |

(1) For applications with RWR devices rated 200 A or more, cable-style connections are recommended.

**Termination**

Allen-Bradley 1321-RWR devices rated 45 amps (fundamental) and below are supplied with an integral mounted terminal block. Devices that are rated 55...160 amps (fundamental) are supplied with box lugs. Devices rated 200...400 amps (fundamental) can be supplied with box lugs or tin-plated aluminum-tabs. Above 400 amps (fundamental), solid tin-plated aluminum-tabs are used.

**Approximate Dimensions, Weights, Wire Size, and Terminal Blocks**

The dimensions and weights that are provided on the following page is for estimating purposes only. Contact your Rockwell Automation sales office if certified drawings are required for planning and installation.

## Approximate Dimensions, Weights, Wire Size, and Terminal Blocks

| Catalog No.    | Fund. | Cont. | VOLTS | Wire Size             | Watts Loss |      | Figure | Dimensions mm (in.) |                   |                  |                |                              |                |                | Weight kg (lb)  |
|----------------|-------|-------|-------|-----------------------|------------|------|--------|---------------------|-------------------|------------------|----------------|------------------------------|----------------|----------------|-----------------|
|                | Amps  | Amps  |       | mm <sup>2</sup> (AWG) | 400V       | 600V |        | A                   | B                 | C                | D              | E                            | F              | G              |                 |
| 1321-RWR8-DP   | 8     | 12    | 400V  | 0.5...16<br>(20...6)  | 377        | 524  | 1      | 282.6<br>(11.13)    | 298.5<br>(11.75)  | 151.13<br>(5.95) | 7.4<br>(0.29)  | 7.4 x 11.6<br>(0.29 x 0.46)  |                |                | 3.81<br>(8.4)   |
| 1321-RWR8-EP   |       |       | 600V  |                       |            |      |        |                     |                   |                  |                |                              |                |                |                 |
| 1321-RWR12-DP  | 12    | 18    | 400V  | 0.5...16<br>(20...6)  | 386        | 401  | 1      | 282.6<br>(11.13)    | 298.5<br>(11.75)  | 151.13<br>(5.95) | 7.4<br>(0.29)  | 7.4 x 11.6<br>(0.29 x 0.46)  |                |                | 4.04<br>(8.9)   |
| 1321-RWR12-EP  |       |       | 600V  |                       |            |      |        |                     |                   |                  |                |                              |                |                |                 |
| 1321-RWR18-DP  | 18    | 27    | 400V  | 0.5...16<br>(20...6)  | 388        | 536  | 1      | 282.6<br>(11.13)    | 298.5<br>(11.75)  | 151.13<br>(5.95) | 7.4<br>(0.29)  | 7.4 x 11.6<br>(0.29 x 0.46)  |                |                | 5.53<br>(12.2)  |
| 1321-RWR18-EP  |       |       | 600V  |                       |            |      |        |                     |                   |                  |                |                              |                |                |                 |
| 1321-RWR25-DP  | 25    | 37.5  | 400V  | 0.5...16<br>(20...6)  | 403        | 553  | 1      | 282.6<br>(11.13)    | 298.5<br>(11.75)  | 176.78<br>(6.96) | 7.4<br>(0.29)  | 7.4 x 11.6<br>(0.29 x 0.46)  |                |                | 6.40<br>(14.1)  |
| 1321-RWR25-EP  |       |       | 600V  |                       |            |      |        |                     |                   |                  |                |                              |                |                |                 |
| 1321-RWR35-DP  | 35    | 52.5  | 400V  | 0.5...16<br>(20...6)  | 411        | 421  | 1      | 282.6<br>(11.13)    | 317.5<br>(12.50)  | 176.78<br>(6.96) | 7.4<br>(0.29)  | 7.4 x 11.6<br>(0.29 x 0.46)  |                |                | 7.17<br>(15.8)  |
| 1321-RWR35-EP  |       |       | 600V  |                       |            |      |        |                     |                   |                  |                |                              |                |                |                 |
| 1321-RWR45-DP  | 45    | 67.5  | 400V  | 0.75...25<br>(18...4) | 406        | 561  | 2      | 320.29<br>(12.61)   | 386.33<br>(15.21) | 158.8<br>(6.25)  | 10.5<br>(0.41) | 10.3 x 17.9<br>(0.41 x 0.70) |                |                | 15.56<br>(34.3) |
| 1321-RWR45-EP  |       |       | 600V  |                       |            |      |        |                     |                   |                  |                |                              |                |                |                 |
| 1321-RWR55-DP  | 55    | 82.5  | 400V  | Per NEC               | 416        | 566  | 3      | 320.7<br>(12.63)    | 370.84<br>(14.6)  | 146.81<br>(5.78) | 10.5<br>(0.41) | 10.3 x 17.9<br>(0.41 x 0.70) | 152.4<br>(6.0) | 190.5<br>(7.5) | 16.10<br>(35.5) |
| 1321-RWR55-EP  |       |       | 600V  |                       |            |      |        |                     |                   |                  |                |                              |                |                |                 |
| 1321-RWR80-DP  | 80    | 120   | 400V  | Per NEC               | 453        | 348  | 3      | 322.3<br>(12.69)    | 382.52<br>(15.06) | 179.58<br>(7.07) | 10.5<br>(0.41) | 10.3 x 17.9<br>(0.41 x 0.70) | 152.4<br>(6.0) | 190.5<br>(7.5) | 20.41<br>(45.0) |
| 1321-RWR80-EP  |       |       | 600V  |                       |            |      |        |                     |                   |                  |                |                              |                |                |                 |
| 1321-RWR100-DP | 100   | 150   | 400V  | Per NEC               | 446        | 361  | 3      | 320.7<br>(12.63)    | 380.49<br>(14.98) | 187.96<br>(7.4)  | 10.5<br>(0.41) | 10.3 x 17.9<br>(0.41 x 0.70) | 152.4<br>(6.0) | 190.5<br>(7.5) | 20.64<br>(45.5) |
| 1321-RWR100-EP |       |       | 600V  |                       |            |      |        |                     |                   |                  |                |                              |                |                |                 |
| 1321-RWR130-DP | 130   | 195   | 400V  | Per NEC               | 575        | 440  | 3      | 317.5<br>(12.50)    | 381.51<br>(15.02) | 312.65<br>(9.12) | 10.5<br>(0.41) | 10.3 x 17.9<br>(0.41 x 0.70) | 152.4<br>(6.0) | 190.5<br>(7.5) | 22.23<br>(49.0) |
| 1321-RWR130-EP |       |       | 600V  |                       |            |      |        |                     |                   |                  |                |                              |                |                |                 |
| 1321-RWR160-DP | 160   | 240   | 400V  | Per NEC               | 574        | 439  | 3      | 355.6<br>(14.00)    | 429.51<br>(16.91) | 229.87<br>(9.05) | 10.5<br>(0.41) | 10.3 x 17.9<br>(0.41 x 0.70) | 182.9<br>(7.2) | 228.6<br>(9.0) | 26.76<br>(59.0) |
| 1321-RWR160-EP |       |       | 600V  |                       |            |      |        |                     |                   |                  |                |                              |                |                |                 |
| 1321-RWR200-DP | 200   | 300   | 400V  | Per NEC               | 600        | 594  | 3      | 317.5<br>(12.50)    | 394.21<br>(15.52) | 245.87<br>(9.68) | 10.5<br>(0.41) | 10.3 x 17.9<br>(0.41 x 0.70) | 152.4<br>(6.0) | 190.5<br>(7.5) | 27.67<br>(61.0) |
| 1321-RWR200-EP |       |       | 600V  |                       |            |      |        |                     |                   |                  |                |                              |                |                |                 |
| 1321-RWR250-DP | 250   | 375   | 400V  | Per NEC               | 577        | 442  | 3      | 358.8<br>(14.13)    | 419.86<br>(16.53) | 274.32<br>(10.8) | 10.5<br>(0.41) | 10.3 x 17.9<br>(0.41 x 0.70) | 182.9<br>(7.2) | 228.6<br>(9.0) | 34.93<br>(77.0) |
| 1321-RWR250-EP |       |       | 600V  |                       |            |      |        |                     |                   |                  |                |                              |                |                |                 |
| 1321-RWR320-DP | 320   | 480   | 400V  | Per NEC               | 458        | N/A  | 3      | 358.8<br>(14.13)    | 429.77<br>(16.92) | 252.22<br>(9.93) | 10.5<br>(0.41) | 10.3 x 17.9<br>(0.41 x 0.70) | 182.9<br>(7.2) | 228.6<br>(9.0) | 43.09<br>(95.0) |

### 1321-RWR Assembly Components

| 400/480V      |                   |       |                 |
|---------------|-------------------|-------|-----------------|
| Reactor       | Resistor          |       | Wire Size (AWG) |
|               | Ohms ( $\Omega$ ) | Watts |                 |
| 1321-3R8-B    | 50                | 250   | 14...12         |
| 1321-3R12-B   | 50                | 250   | 14...12         |
| 1321-3R18-B   | 50                | 250   | 14...12         |
| 1321-3R25-B   | 50                | 250   | 10              |
| 1321-3R35-B   | 50                | 250   | 8...6           |
| 1321-3R45-B   | 50                | 250   | 6               |
| 1321-3R55-B   | 50                | 250   | 4               |
| 1321-3R80-B   | 50                | 250   | 2/0             |
| 1321-3R100-B  | 50                | 250   | 2/0             |
| 1321-3R130-B  | 50                | 300   | 2/0             |
| 1321-3R160-B  | 50                | 300   | 4/0             |
| 1321-3R200-B  | 50                | 300   | 250 MCM         |
| 1321-3RB250-B | 50                | 300   | 350 MCM         |
| 1321-3R320-B  | 50                | 300   | 500 MCM         |

| 600V          |                   |       |                 |
|---------------|-------------------|-------|-----------------|
| Reactor       | Resistor          |       | Wire Size (AWG) |
|               | Ohms ( $\Omega$ ) | Watts |                 |
| 1321-3R8-B    | 50                | 360   | 14...12         |
| 1321-3R12-B   | 50                | 360   | 14...12         |
| 1321-3R18-B   | 50                | 360   | 14...12         |
| 1321-3R25-B   | 50                | 360   | 10              |
| 1321-3R35-B   | 50                | 360   | 8...6           |
| 1321-3R45-B   | 50                | 360   | 6               |
| 1321-3R55-B   | 50                | 375   | 4               |
| 1321-3R80-B   | 50                | 375   | 2/0             |
| 1321-3R100-B  | 50                | 375   | 2/0             |
| 1321-3R130-B  | 50                | 420   | 2/0             |
| 1321-3R160-B  | 50                | 420   | 4/0             |
| 1321-3R200-B  | 50                | 420   | 250 MCM         |
| 1321-3RB250-B | 50                | 420   | 350 MCM         |

### Terminal Block Details

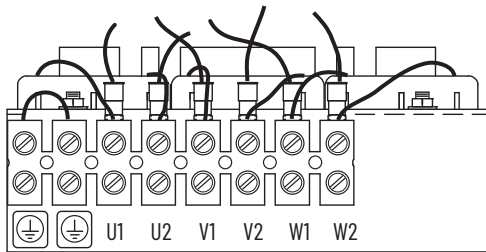

Details Figure 1 and Figure 2

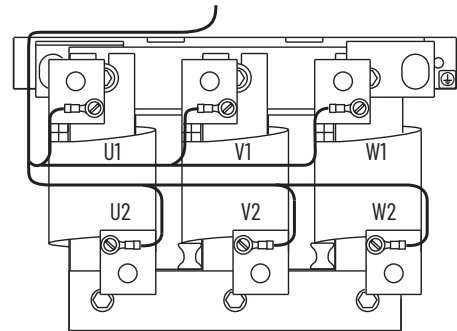

Details Figure 3

### Dimension Reference

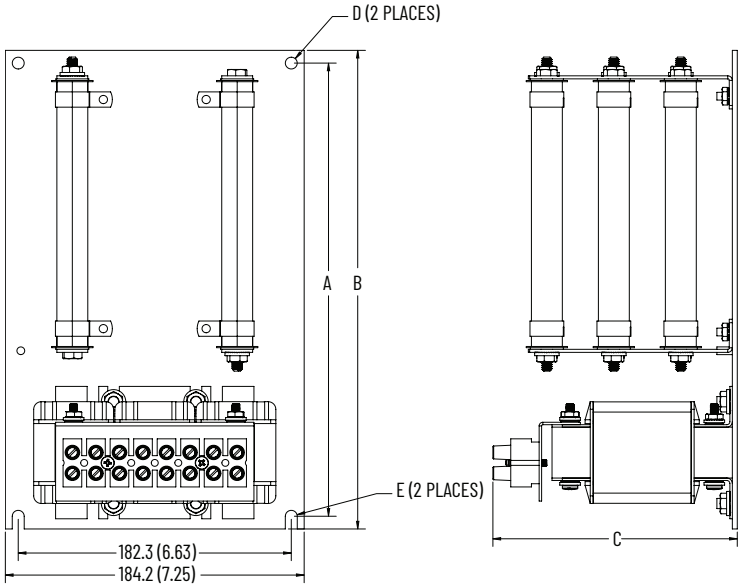

Figure 1

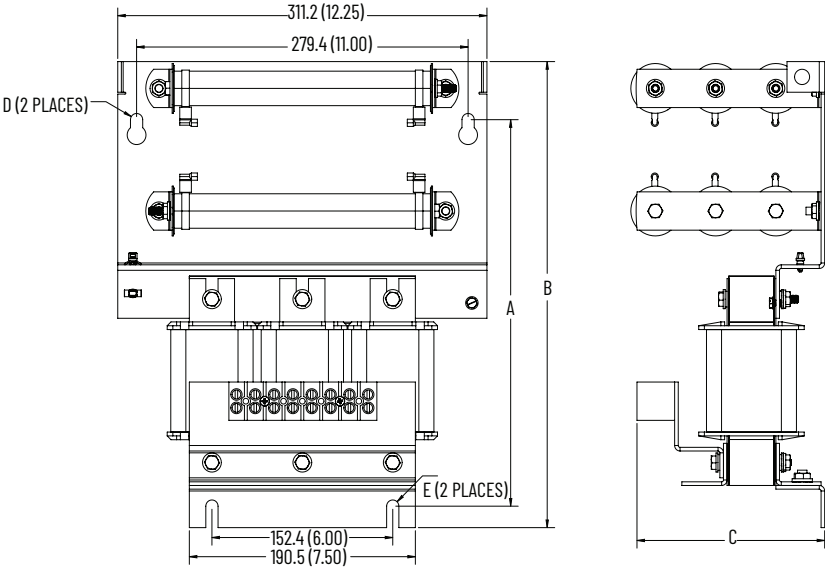

Figure 2

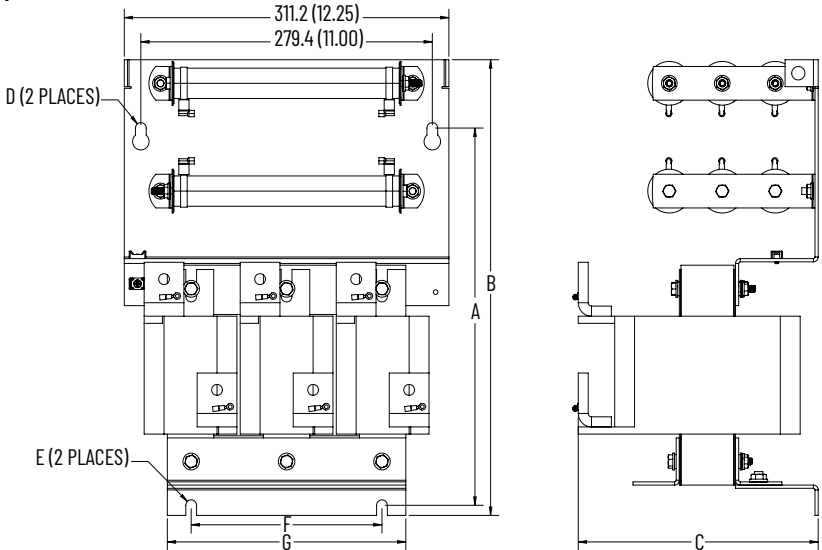
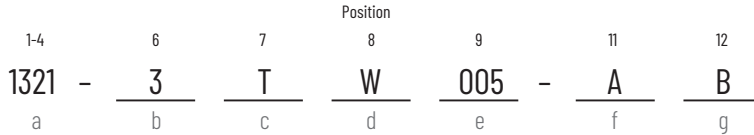

Figure 3

# 1321-3TH/3TW Series Three-Phase Isolation Transformers

Allen-Bradley 1321 Isolation Transformers are designed to meet the standard horsepower, voltage ratings, and harmonics of the Allen-Bradley variable speed drives.

## Catalog Number Explanation



| a<br>Product |                 |
|--------------|-----------------|
| Code         | Type            |
| 1321         | Power Component |

| b<br>Phases |             |
|-------------|-------------|
| Code        | Description |
| 3           | Three-Phase |

| c<br>Device |             |
|-------------|-------------|
| Code        | Description |
| T           | Transformer |

| d<br>Mounting |             |
|---------------|-------------|
| Code          | Description |
| W *           | Wall        |
| H             | Floor       |

\* These ship with an additional bracket which allows wall mounting.

| e<br>Rating |     |
|-------------|-----|
| Code        | kVA |
| 005         | 5   |
| 007         | 7.5 |
| 011         | 11  |
| 014         | 14  |
| 020         | 20  |
| 027         | 27  |
| 034         | 34  |
| 040         | 40  |
| 051         | 51  |
| 063         | 63  |
| 075         | 75  |
| 093         | 93  |
| 118         | 118 |
| 145         | 145 |
| 175         | 175 |
| 220         | 220 |
| 275         | 275 |
| 330         | 330 |
| 440         | 440 |
| 550         | 550 |
| 660         | 660 |
| 770         | 770 |
| 880         | 880 |

| f<br>Primary Voltage |         |
|----------------------|---------|
| Code                 | Voltage |
| A                    | 230V AC |
| B                    | 460V AC |
| C                    | 575V AC |
| X                    | 208V AC |

| g<br>Secondary Voltage |         |
|------------------------|---------|
| Code                   | Voltage |
| A                      | 230V AC |
| B                      | 460V AC |
| C                      | 575V AC |
| X                      | 208V AC |

## Specifications

### Specifications

| Specification | Rating                           |  |
|---------------|----------------------------------|--|
| Electrical    | General                          | Delta primary, wye secondary, 60 Hz, aluminum wound, neutral terminal available for customer use |
|               | Standard Voltage Taps            | 5.0...175 kVA, 1...5.0% FCAN and FCBN  |
|               |                                  | 220...880 kVA, 1...2.5% FCAN and FCBN ±10%   |
|               | Insulation System                | Class 220  |
|               |                                  | 150 °C rise over 40 °C ambient<br>Peak 40 °C ambient with 30 °C 24-hour average                  |
| Efficiency    | 98% (2% losses)                  |  |
| Environmental | Elevation                        | Up to 1000 meters. Above 1000 meters, consult factory for derating                               |
|               | U.L. Listed                      | File E112313   |
|               | Storage Temperature (all const.) | -40...+70°C (-40...+158°F)   |
|               | Humidity                         | 5...95% noncondensing  |

Specifications (Continued)

| Specification |                          | Rating   |
|---------------|--------------------------|--|
| Construction  | Enclosure                | NEMA/UL Type 3R (IP32)   |
|               |                          | Heavy duty ventilated enclosure with metal screens that help protect all vents and finished in ANSI 61 grey  |
|               | Termination              | Transformers up to 75 kVA have integral high and low voltage lugs that are installed, suitable for copper or aluminum cable installation   |
|               | Conduit Entry            | Standard knockouts on all enclosures   |
| General       | Mounting                 | 5...51 kVA units suitable for either floor or wall mounting. 63...75 kVA units suitable for floor, wall, or ceiling mounting with mounting kit 1321-3TWM2 (Style NH3). Larger units are floor mount only |
|               | Impedance                | 4...6% impedance (nominal)   |
|               | Short Circuit Capability | Meets UL short circuit withstand capability  |
|               | Overload Rating          | Windings that are designed to withstand overcurrent of 150% of rated load for 60 Seconds or 200% of rated load for 30 Seconds  |
|               | Duty Cycle               | (1) start every (2) hours  |
|               | Thermostats              | Thermostats with 1 N.C. contact in each coil, which are wired in series and integral on all units  |
|               | K-factor                 | 4  |

Approximate Mounting Dimensions

IP32, NEMA/UL Type 3R - Styles NH3 Through NH4

Dimensions in mm (in.)

| Style   | A                | Overall A        | B                | Overall B        | C                | D                | H                | K                         | MA               | MB               | WMB             | WMA             |
|---------|------------------|------------------|------------------|------------------|------------------|------------------|------------------|---------------------------|------------------|------------------|-----------------|-----------------|
| NH3     | 660.4<br>(26.00) | —                | 533.4<br>(21.00) | 635.0<br>(25.00) | 66.0<br>(38.00)  | 609.6<br>(24.00) | 355.6<br>(14.00) | 50.8 x 76.2 (2.00 x 3.00) | 546.1<br>(21.50) | 482.6<br>(19.00) | —               | —               |
| NH4     | 812.8<br>(32.00) | —                | 647.7<br>(25.50) | 749.3<br>(29.50) | 68.0<br>(41.00)  | 609.6<br>(24.00) | 304.8<br>(12.00) | 50.8 x 76.2 (2.00 x 3.00) | 596.9<br>(23.50) | 596.9<br>(23.50) | —               | —               |
| NH5 (1) | 425.5<br>(16.75) | 492.8<br>(19.40) | 381.0<br>(15.00) | 513.1<br>(20.20) | 546.1 (21.50)    | 304.8<br>(12.00) | 152.4<br>(6.00)  | 35.1 x 44.4 (1.38 x 1.75) | 457.2<br>(18.00) | 228.6<br>(9.00)  | 177.8<br>(7.00) | 184.4<br>(7.26) |
| NH6 (1) | 546.1 (21.50)    | 607.1<br>(23.90) | 495.3<br>(19.50) | 730.3<br>(28.75) | 730.3<br>(28.75) | 431.8<br>(17.00) | 215.9<br>(8.50)  | 35.1 x 44.4 (1.38 x 1.75) | 577.9<br>(22.75) | 228.6<br>(9.00)  | 203.2<br>(8.00) | 247.1<br>(9.73) |

(1) Enclosure Styles NH1 and NH2 are replaced by NH5 and NH6 for 1321-3TH005 through 1321-3TH051 transformer ratings.

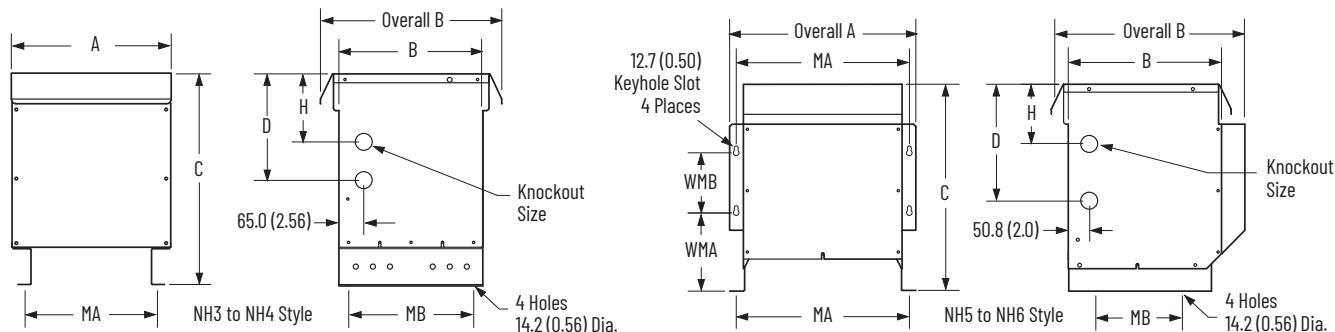

IP32, NEMA/UL Type 3R - Styles NJ1 Through NJ6

Dimensions in mm (in.)

| Style | A                 | B                 | C                 | D                | E                | F                | G                | H               | K                | M                 | MA                | MB                |
|-------|-------------------|-------------------|-------------------|------------------|------------------|------------------|------------------|-----------------|------------------|-------------------|-------------------|-------------------|
| NJ1   | 1003.3<br>(39.50) | 762.0<br>(30.00)  | 1308.1<br>(51.50) | 254.0<br>(10.00) | 190.5<br>(7.50)  | 546.1 (21.50)    | 203.2<br>(8.00)  | 165.1<br>(6.50) | 342.9<br>(13.50) | 863.6<br>(34.00)  | 609.6<br>(24.00)  | 812.8<br>(32.00)  |
| NJ2   | 1239.1<br>(48.50) | 836.6<br>(34.00)  | 1498.6<br>(59.00) | 330.2<br>(13.00) | 215.9<br>(8.50)  | 635.0<br>(25.00) | 228.6<br>(9.00)  | 215.9<br>(8.50) | 393.7<br>(15.50) | 965.2<br>(38.00)  | 698.5<br>(27.50)  | 914.4<br>(36.00)  |
| NJ3   | 1308.1<br>(51.50) | 990.6<br>(39.00)  | 1676.4<br>(66.00) | 406.4<br>(16.00) | 241.3<br>(9.50)  | 800.1 (31.50)    | 254.0<br>(10.00) | 292.1 (11.50)   | 457.2<br>(18.00) | 1092.2<br>(43.00) | 863.6<br>(34.00)  | 1041.4<br>(41.00) |
| NJ6   | 1625.6<br>(64.00) | 1016.0<br>(40.00) | 1727.2<br>(68.00) | 406.4<br>(16.00) | 266.7<br>(10.50) | 952.5<br>(37.50) | 279.4<br>(11.00) | 292.1 (11.50)   | 457.2<br>(18.00) | 1117.6 (44.00)    | 1016.0<br>(40.00) | 1066.8<br>(42.00) |

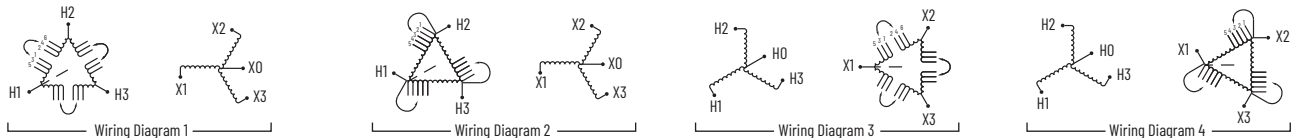
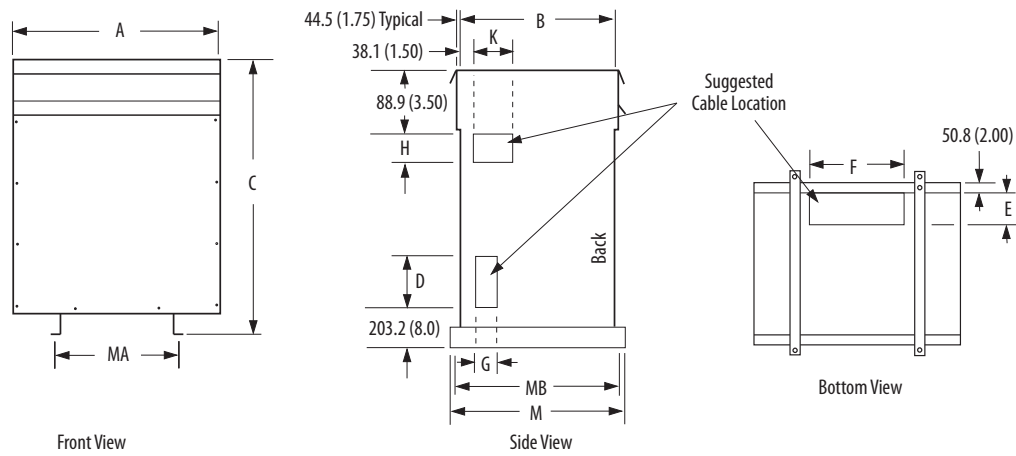

Wiring Diagrams, Ratings, and Weights

| kVA | Catalog Number | Style | Primary Voltage | Secondary Voltage | Wiring Diagram | Weight kg (lbs.) |
|-----|----------------|-------|-----------------|-------------------|----------------|------------------|
| 5   | 1321-3TW005-AA | NH5   | 230             | 230               | 1              | 63.5 (140)       |
|     | 1321-3TW005-AB | NH5   | 230             | 460               | 3              | 63.5 (140)       |
|     | 1321-3TW005-AC | NH5   | 230             | 575               | 3              | 63.5 (140)       |
|     | 1321-3TW005-BA | NH5   | 460             | 230               | 1              | 63.5 (140)       |
|     | 1321-3TW005-BB | NH5   | 460             | 460               | 1              | 63.5 (140)       |
|     | 1321-3TW005-BC | NH5   | 460             | 575               | 3              | 63.5 (140)       |
|     | 1321-3TW005-CA | NH5   | 575             | 230               | 1              | 63.5 (140)       |
|     | 1321-3TW005-CB | NH5   | 575             | 460               | 1              | 63.5 (140)       |
|     | 1321-3TW005-CC | NH5   | 575             | 575               | 1              | 63.5 (140)       |
|     | 1321-3TW005-XX | NH5   | 208             | 208               | 1              | 63.5 (140)       |
| 7.5 | 1321-3TW007-AA | NH5   | 230             | 230               | 1              | 63.5 (140)       |
|     | 1321-3TW007-AB | NH5   | 230             | 460               | 3              | 63.5 (140)       |
|     | 1321-3TW007-AC | NH5   | 230             | 575               | 3              | 63.5 (140)       |
|     | 1321-3TW007-BA | NH5   | 460             | 230               | 1              | 63.5 (140)       |
|     | 1321-3TW007-BB | NH5   | 460             | 460               | 1              | 63.5 (140)       |
|     | 1321-3TW007-BC | NH5   | 460             | 575               | 3              | 63.5 (140)       |
|     | 1321-3TW007-CA | NH5   | 575             | 230               | 1              | 63.5 (140)       |
|     | 1321-3TW007-CB | NH5   | 575             | 460               | 1              | 63.5 (140)       |
|     | 1321-3TW007-CC | NH5   | 575             | 575               | 1              | 63.5 (140)       |
|     | 1321-3TW007-XX | NH5   | 208             | 208               | 1              | 63.5 (140)       |

| kVA | Catalog Number | Style | Primary Voltage | Secondary Voltage | Wiring Diagram | Weight kg (lbs.) |
|-----|----------------|-------|-----------------|-------------------|----------------|------------------|
| 11  | 1321-3TW011-AA | NH5   | 230             | 230               | 1              | 70.3 (155)       |
|     | 1321-3TW011-AB | NH5   | 230             | 460               | 3              | 70.3 (155)       |
|     | 1321-3TW011-AC | NH5   | 230             | 575               | 3              | 70.3 (155)       |
|     | 1321-3TW011-BA | NH5   | 460             | 230               | 1              | 70.3 (155)       |
|     | 1321-3TW011-BB | NH5   | 460             | 460               | 1              | 70.3 (155)       |
|     | 1321-3TW011-BC | NH5   | 460             | 575               | 3              | 70.3 (155)       |
|     | 1321-3TW011-CA | NH5   | 575             | 230               | 1              | 70.3 (155)       |
|     | 1321-3TW011-CB | NH5   | 575             | 460               | 1              | 70.3 (155)       |
|     | 1321-3TW011-CC | NH5   | 575             | 575               | 1              | 70.3 (155)       |
|     | 1321-3TW011-XX | NH5   | 208             | 208               | 1              | 70.3 (155)       |
| 14  | 1321-3TW014-AA | NH5   | 230             | 230               | 1              | 79.4 (175)       |
|     | 1321-3TW014-AB | NH5   | 230             | 460               | 3              | 79.4 (175)       |
|     | 1321-3TW014-AC | NH5   | 230             | 575               | 3              | 79.4 (175)       |
|     | 1321-3TW014-BA | NH5   | 460             | 230               | 1              | 79.4 (175)       |
|     | 1321-3TW014-BB | NH5   | 460             | 460               | 1              | 79.4 (175)       |
|     | 1321-3TW014-BC | NH5   | 460             | 575               | 3              | 79.4 (175)       |
|     | 1321-3TW014-CA | NH5   | 575             | 230               | 1              | 79.4 (175)       |
|     | 1321-3TW014-CB | NH5   | 575             | 460               | 1              | 79.4 (175)       |
|     | 1321-3TW014-CC | NH5   | 575             | 575               | 1              | 79.4 (175)       |
|     | 1321-3TW014-XX | NH5   | 208             | 208               | 1              | 79.4 (175)       |

continued on next page

Wiring Diagrams, Ratings, and Weights (Continued)

| kVA | Catalog Number | Style | Primary Voltage | Secondary Voltage | Wiring Diagram | Weight kg (lbs.) |
|-----|----------------|-------|-----------------|-------------------|----------------|------------------|
| 20  | 1321-3TW020-AA | NH6   | 230             | 230               | 2              | 104.3 (230)      |
|     | 1321-3TW020-AB | NH6   | 230             | 460               | 4              | 104.3 (230)      |
|     | 1321-3TW020-AC | NH6   | 230             | 575               | 4              | 104.3 (230)      |
|     | 1321-3TW020-BA | NH6   | 460             | 230               | 2              | 104.3 (230)      |
|     | 1321-3TW020-BB | NH6   | 460             | 460               | 2              | 104.3 (230)      |
|     | 1321-3TW020-BC | NH6   | 460             | 575               | 4              | 104.3 (230)      |
|     | 1321-3TW020-CA | NH6   | 575             | 230               | 2              | 104.3 (230)      |
|     | 1321-3TW020-CB | NH6   | 575             | 460               | 2              | 104.3 (230)      |
|     | 1321-3TW020-CC | NH6   | 575             | 575               | 2              | 104.3 (230)      |
|     | 1321-3TW020-XX | NH6   | 208             | 208               | 2              | 104.3 (230)      |
| 27  | 1321-3TW027-AA | NH6   | 230             | 230               | 2              | 113.4 (250)      |
|     | 1321-3TW027-AB | NH6   | 230             | 460               | 4              | 113.4 (250)      |
|     | 1321-3TW027-AC | NH6   | 230             | 575               | 4              | 113.4 (250)      |
|     | 1321-3TW027-BA | NH6   | 460             | 230               | 2              | 113.4 (250)      |
|     | 1321-3TW027-BB | NH6   | 460             | 460               | 2              | 113.4 (250)      |
|     | 1321-3TW027-BC | NH6   | 460             | 575               | 4              | 113.4 (250)      |
|     | 1321-3TW027-CA | NH6   | 575             | 230               | 2              | 113.4 (250)      |
|     | 1321-3TW027-CB | NH6   | 575             | 460               | 2              | 113.4 (250)      |
|     | 1321-3TW027-CC | NH6   | 575             | 575               | 2              | 113.4 (250)      |
|     | 1321-3TW027-XX | NH6   | 208             | 208               | 2              | 113.4 (250)      |
| 34  | 1321-3TW034-AA | NH6   | 230             | 230               | 2              | 127.0 (280)      |
|     | 1321-3TW034-AB | NH6   | 230             | 460               | 4              | 127.0 (280)      |
|     | 1321-3TW034-AC | NH6   | 230             | 575               | 4              | 127.0 (280)      |
|     | 1321-3TW034-BA | NH6   | 460             | 230               | 2              | 127.0 (280)      |
|     | 1321-3TW034-BB | NH6   | 460             | 460               | 2              | 127.0 (280)      |
|     | 1321-3TW034-BC | NH6   | 460             | 575               | 4              | 127.0 (280)      |
|     | 1321-3TW034-CA | NH6   | 575             | 230               | 2              | 127.0 (280)      |
|     | 1321-3TW034-CB | NH6   | 575             | 460               | 2              | 127.0 (280)      |
|     | 1321-3TW034-CC | NH6   | 575             | 575               | 2              | 127.0 (280)      |
|     | 1321-3TW034-XX | NH6   | 208             | 208               | 2              | 127.0 (280)      |

| kVA | Catalog Number | Style | Primary Voltage | Secondary Voltage | Wiring Diagram | Weight kg (lbs.) |
|-----|----------------|-------|-----------------|-------------------|----------------|------------------|
| 40  | 1321-3TW040-AA | NH6   | 230             | 230               | 2              | 145.2 (320)      |
|     | 1321-3TW040-AB | NH6   | 230             | 460               | 4              | 145.2 (320)      |
|     | 1321-3TW040-AC | NH6   | 230             | 575               | 4              | 145.2 (320)      |
|     | 1321-3TW040-BA | NH6   | 460             | 230               | 2              | 145.2 (320)      |
|     | 1321-3TW040-BB | NH6   | 460             | 460               | 2              | 145.2 (320)      |
|     | 1321-3TW040-BC | NH6   | 460             | 575               | 4              | 145.2 (320)      |
|     | 1321-3TW040-CA | NH6   | 575             | 230               | 2              | 145.2 (320)      |
|     | 1321-3TW040-CB | NH6   | 575             | 460               | 2              | 145.2 (320)      |
|     | 1321-3TW040-CC | NH6   | 575             | 575               | 2              | 145.2 (320)      |
|     | 1321-3TW040-XX | NH6   | 208             | 208               | 2              | 145.2 (320)      |
| 51  | 1321-3TW051-AA | NH6   | 230             | 230               | 2              | 190.5 (420)      |
|     | 1321-3TW051-AB | NH6   | 230             | 460               | 4              | 190.5 (420)      |
|     | 1321-3TW051-AC | NH6   | 230             | 575               | 4              | 190.5 (420)      |
|     | 1321-3TW051-BA | NH6   | 460             | 230               | 2              | 190.5 (420)      |
|     | 1321-3TW051-BB | NH6   | 460             | 460               | 2              | 190.5 (420)      |
|     | 1321-3TW051-BC | NH6   | 460             | 575               | 4              | 190.5 (420)      |
|     | 1321-3TW051-CA | NH6   | 575             | 230               | 2              | 190.5 (420)      |
|     | 1321-3TW051-CB | NH6   | 575             | 460               | 2              | 190.5 (420)      |
|     | 1321-3TW051-CC | NH6   | 575             | 575               | 2              | 190.5 (420)      |
|     | 1321-3TW051-XX | NH6   | 208             | 208               | 2              | 190.5 (420)      |
| 63  | 1321-3TH063-AA | NH3   | 230             | 230               | 2              | 244.9 (540)      |
|     | 1321-3TH063-AB | NH3   | 230             | 460               | 4              | 244.9 (540)      |
|     | 1321-3TH063-AC | NH3   | 230             | 575               | 4              | 244.9 (540)      |
|     | 1321-3TH063-BA | NH3   | 460             | 230               | 2              | 244.9 (540)      |
|     | 1321-3TH063-BB | NH3   | 460             | 460               | 2              | 244.9 (540)      |
|     | 1321-3TH063-BC | NH3   | 460             | 575               | 4              | 244.9 (540)      |
|     | 1321-3TH063-CA | NH3   | 575             | 230               | 2              | 244.9 (540)      |
|     | 1321-3TH063-CB | NH3   | 575             | 460               | 2              | 244.9 (540)      |
|     | 1321-3TH063-CC | NH3   | 575             | 575               | 2              | 244.9 (540)      |
|     | 1321-3TH063-XX | NH3   | 208             | 208               | 2              | 244.9 (540)      |
| 75  | 1321-3TH075-AA | NH3   | 230             | 230               | 2              | 263.1 (580)      |
|     | 1321-3TH075-AB | NH3   | 230             | 460               | 4              | 263.1 (580)      |
|     | 1321-3TH075-AC | NH3   | 230             | 575               | 4              | 263.1 (580)      |
|     | 1321-3TH075-BA | NH3   | 460             | 230               | 2              | 263.1 (580)      |
|     | 1321-3TH075-BB | NH3   | 460             | 460               | 2              | 263.1 (580)      |
|     | 1321-3TH075-BC | NH3   | 460             | 575               | 4              | 263.1 (580)      |
|     | 1321-3TH075-CA | NH3   | 575             | 230               | 2              | 263.1 (580)      |
|     | 1321-3TH075-CB | NH3   | 575             | 460               | 2              | 263.1 (580)      |
|     | 1321-3TH075-CC | NH3   | 575             | 575               | 2              | 263.1 (580)      |
|     | 1321-3TH075-XX | NH3   | 208             | 208               | 2              | 263.1 (580)      |

continued on next page

Wiring Diagrams, Ratings, and Weights (Continued)

| kVA | Catalog Number | Style | Primary Voltage | Secondary Voltage | Wiring Diagram | Weight kg (lbs.) |
|-----|----------------|-------|-----------------|-------------------|----------------|------------------|
| 93  | 1321-3TH093-AA | NH3   | 230             | 230               | 2              | 285.8 (630)      |
|     | 1321-3TH093-AB | NH3   | 230             | 460               | 4              | 285.8 (630)      |
|     | 1321-3TH093-AC | NH3   | 230             | 575               | 4              | 285.8 (630)      |
|     | 1321-3TH093-BA | NH3   | 460             | 230               | 2              | 285.8 (630)      |
|     | 1321-3TH093-BB | NH3   | 460             | 460               | 2              | 285.8 (630)      |
|     | 1321-3TH093-BC | NH3   | 460             | 575               | 4              | 285.8 (630)      |
|     | 1321-3TH093-CA | NH3   | 575             | 230               | 2              | 285.8 (630)      |
|     | 1321-3TH093-CB | NH3   | 575             | 460               | 2              | 285.8 (630)      |
|     | 1321-3TH093-CC | NH3   | 575             | 575               | 2              | 285.8 (630)      |
| 118 | 1321-3TH118-AA | NH3   | 230             | 230               | 2              | 328.9 (725)      |
|     | 1321-3TH118-AB | NH3   | 230             | 460               | 4              | 328.9 (725)      |
|     | 1321-3TH118-AC | NH3   | 230             | 575               | 4              | 328.9 (725)      |
|     | 1321-3TH118-BA | NH3   | 460             | 230               | 2              | 328.9 (725)      |
|     | 1321-3TH118-BB | NH3   | 460             | 460               | 2              | 328.9 (725)      |
|     | 1321-3TH118-BC | NH3   | 460             | 575               | 4              | 328.9 (725)      |
|     | 1321-3TH118-CA | NH3   | 575             | 230               | 2              | 328.9 (725)      |
|     | 1321-3TH118-CB | NH3   | 575             | 460               | 2              | 328.9 (725)      |
|     | 1321-3TH118-CC | NH3   | 575             | 575               | 2              | 328.9 (725)      |
| 145 | 1321-3TH145-AA | NH4   | 230             | 230               | 2              | 408.2 (900)      |
|     | 1321-3TH145-AB | NH4   | 230             | 460               | 4              | 408.2 (900)      |
|     | 1321-3TH145-AC | NH4   | 230             | 575               | 4              | 408.2 (900)      |
|     | 1321-3TH145-BA | NH4   | 460             | 230               | 2              | 408.2 (900)      |
|     | 1321-3TH145-BB | NH4   | 460             | 460               | 2              | 408.2 (900)      |
|     | 1321-3TH145-BC | NH4   | 460             | 575               | 4              | 408.2 (900)      |
|     | 1321-3TH145-CA | NH4   | 575             | 230               | 2              | 408.2 (900)      |
|     | 1321-3TH145-CB | NH4   | 575             | 460               | 2              | 408.2 (900)      |
|     | 1321-3TH145-CC | NH4   | 575             | 575               | 2              | 408.2 (900)      |
| 175 | 1321-3TH175-AA | NH4   | 230             | 230               | 2              | 453.6 (1000)     |
|     | 1321-3TH175-AB | NH4   | 230             | 460               | 4              | 453.6 (1000)     |
|     | 1321-3TH175-AC | NH4   | 230             | 575               | 4              | 453.6 (1000)     |
|     | 1321-3TH175-BA | NH4   | 460             | 230               | 2              | 453.6 (1000)     |
|     | 1321-3TH175-BB | NH4   | 460             | 460               | 2              | 453.6 (1000)     |
|     | 1321-3TH175-BC | NH4   | 460             | 575               | 4              | 453.6 (1000)     |
|     | 1321-3TH175-CA | NH4   | 575             | 230               | 2              | 453.6 (1000)     |
|     | 1321-3TH175-CB | NH4   | 575             | 460               | 2              | 453.6 (1000)     |
|     | 1321-3TH175-CC | NH4   | 575             | 575               | 2              | 453.6 (1000)     |
| 220 | 1321-3TH220-AA | NJ1   | 230             | 230               | 2              | 589.7 (1300)     |
|     | 1321-3TH220-AB | NJ1   | 230             | 460               | 4              | 589.7 (1300)     |
|     | 1321-3TH220-AC | NJ1   | 230             | 575               | 4              | 589.7 (1300)     |
|     | 1321-3TH220-BA | NJ1   | 460             | 230               | 2              | 589.7 (1300)     |
|     | 1321-3TH220-BB | NJ1   | 460             | 460               | 2              | 589.7 (1300)     |
|     | 1321-3TH220-BC | NJ1   | 460             | 575               | 4              | 589.7 (1300)     |
|     | 1321-3TH220-CA | NJ1   | 575             | 230               | 2              | 589.7 (1300)     |
|     | 1321-3TH220-CB | NJ1   | 575             | 460               | 2              | 589.7 (1300)     |
|     | 1321-3TH220-CC | NJ1   | 575             | 575               | 2              | 589.7 (1300)     |

| kVA | Catalog Number | Style | Primary Voltage | Secondary Voltage | Wiring Diagram | Weight kg (lbs.) |
|-----|----------------|-------|-----------------|-------------------|----------------|------------------|
| 275 | 1321-3TH275-AA | NJ1   | 230             | 230               | 2              | 680.4 (1500)     |
|     | 1321-3TH275-AB | NJ1   | 230             | 460               | 4              | 680.4 (1500)     |
|     | 1321-3TH275-AC | NJ1   | 230             | 575               | 4              | 680.4 (1500)     |
|     | 1321-3TH275-BA | NJ1   | 460             | 230               | 2              | 680.4 (1500)     |
|     | 1321-3TH275-BB | NJ1   | 460             | 460               | 2              | 680.4 (1500)     |
|     | 1321-3TH275-BC | NJ1   | 460             | 575               | 4              | 680.4 (1500)     |
|     | 1321-3TH275-CA | NJ1   | 575             | 230               | 2              | 680.4 (1500)     |
|     | 1321-3TH275-CB | NJ1   | 575             | 460               | 2              | 680.4 (1500)     |
|     | 1321-3TH275-CC | NJ1   | 575             | 575               | 2              | 680.4 (1500)     |
| 330 | 1321-3TH330-AA | NJ1   | 230             | 230               | 2              | 771.1 (1700)     |
|     | 1321-3TH330-AB | NJ1   | 230             | 460               | 4              | 771.1 (1700)     |
|     | 1321-3TH330-AC | NJ1   | 230             | 575               | 4              | 771.1 (1700)     |
|     | 1321-3TH330-BA | NJ1   | 460             | 230               | 2              | 771.1 (1700)     |
|     | 1321-3TH330-BB | NJ1   | 460             | 460               | 2              | 771.1 (1700)     |
|     | 1321-3TH330-BC | NJ1   | 460             | 575               | 4              | 771.1 (1700)     |
|     | 1321-3TH330-CA | NJ1   | 575             | 230               | 2              | 771.1 (1700)     |
|     | 1321-3TH330-CB | NJ1   | 575             | 460               | 2              | 771.1 (1700)     |
|     | 1321-3TH330-CC | NJ1   | 575             | 575               | 2              | 771.1 (1700)     |
| 440 | 1321-3TH440-AA | NJ2   | 230             | 230               | 1              | 907.2 (2000)     |
|     | 1321-3TH440-AB | NJ2   | 230             | 460               | 3              | 907.2 (2000)     |
|     | 1321-3TH440-AC | NJ2   | 230             | 575               | 3              | 907.2 (2000)     |
|     | 1321-3TH440-BA | NJ2   | 460             | 230               | 1              | 907.2 (2000)     |
|     | 1321-3TH440-BB | NJ2   | 460             | 460               | 1              | 907.2 (2000)     |
|     | 1321-3TH440-BC | NJ2   | 460             | 575               | 3              | 907.2 (2000)     |
|     | 1321-3TH440-CA | NJ2   | 575             | 230               | 1              | 907.2 (2000)     |
|     | 1321-3TH440-CB | NJ2   | 575             | 460               | 1              | 907.2 (2000)     |
|     | 1321-3TH440-CC | NJ2   | 575             | 575               | 1              | 907.2 (2000)     |
| 550 | 1321-3TH550-AA | NJ2   | 230             | 230               | 1              | 1134.0 (2500)    |
|     | 1321-3TH550-AB | NJ2   | 230             | 460               | 3              | 1134.0 (2500)    |
|     | 1321-3TH550-AC | NJ2   | 230             | 575               | 3              | 1134.0 (2500)    |
|     | 1321-3TH550-BA | NJ2   | 460             | 230               | 1              | 1134.0 (2500)    |
|     | 1321-3TH550-BB | NJ2   | 460             | 460               | 1              | 1134.0 (2500)    |
|     | 1321-3TH550-BC | NJ2   | 460             | 575               | 3              | 1134.0 (2500)    |
|     | 1321-3TH550-CA | NJ2   | 575             | 230               | 1              | 1134.0 (2500)    |
|     | 1321-3TH550-CB | NJ2   | 575             | 460               | 1              | 1134.0 (2500)    |
|     | 1321-3TH550-CC | NJ2   | 575             | 575               | 1              | 1134.0 (2500)    |

continued on next page

Wiring Diagrams, Ratings, and Weights (Continued)

| kVA | Catalog Number | Style | Primary Voltage | Secondary Voltage | Wiring Diagram | Weight kg (lbs.) |
|-----|----------------|-------|-----------------|-------------------|----------------|------------------|
| 660 | 1321-3TH660-AA | NJ3   | 230             | 230               | 1              | 1360.8 (3000)    |
|     | 1321-3TH660-AB | NJ3   | 230             | 460               | 3              | 1360.8 (3000)    |
|     | 1321-3TH660-AC | NJ3   | 230             | 575               | 3              | 1360.8 (3000)    |
|     | 1321-3TH660-BA | NJ3   | 460             | 230               | 1              | 1360.8 (3000)    |
|     | 1321-3TH660-BB | NJ3   | 460             | 460               | 1              | 1360.8 (3000)    |
|     | 1321-3TH880-BC | NJ6   | 460             | 575               | 3              | 1678.3 (3700)    |
|     | 1321-3TH880-CA | NJ6   | 575             | 230               | 1              | 1678.3 (3700)    |
|     | 1321-3TH880-CB | NJ6   | 575             | 460               | 1              | 1678.3 (3700)    |
|     | 1321-3TH880-CC | NJ6   | 575             | 575               | 1              | 1678.3 (3700)    |
|     | 1321-3TH660-BC | NJ3   | 460             | 575               | 3              | 1360.8 (3000)    |
|     | 1321-3TH660-CA | NJ3   | 575             | 230               | 1              | 1360.8 (3000)    |
|     | 1321-3TH660-CB | NJ3   | 575             | 460               | 1              | 1360.8 (3000)    |
|     | 1321-3TH660-CC | NJ3   | 575             | 575               | 1              | 1360.8 (3000)    |

| kVA            | Catalog Number | Style          | Primary Voltage | Secondary Voltage | Wiring Diagram | Weight kg (lbs.) |
|----------------|----------------|----------------|-----------------|-------------------|----------------|------------------|
| 770            | 1321-3TH770-AA | NJ3            | 230             | 230               | 1              | 1587.6 (3500)    |
|                | 1321-3TH770-AB | NJ3            | 230             | 460               | 3              | 1587.6 (3500)    |
|                | 1321-3TH770-AC | NJ3            | 230             | 575               | 3              | 1587.6 (3500)    |
|                | 1321-3TH770-BA | NJ3            | 460             | 230               | 1              | 1587.6 (3500)    |
|                | 1321-3TH770-BB | NJ3            | 460             | 460               | 1              | 1587.6 (3500)    |
|                | 1321-3TH770-BC | NJ3            | 460             | 575               | 3              | 1587.6 (3500)    |
|                | 1321-3TH770-CA | NJ3            | 575             | 230               | 1              | 1587.6 (3500)    |
|                | 1321-3TH770-CB | NJ3            | 575             | 460               | 1              | 1587.6 (3500)    |
|                | 1321-3TH770-CC | NJ3            | 575             | 575               | 1              | 1587.6 (3500)    |
|                | 880            | 1321-3TH880-AA | NJ6             | 230               | 230            | 1                |
| 1321-3TH880-AB |                | NJ6            | 230             | 460               | 3              | 1678.3 (3700)    |
| 1321-3TH880-AC |                | NJ6            | 230             | 575               | 3              | 1678.3 (3700)    |
| 1321-3TH880-BA |                | NJ6            | 460             | 230               | 1              | 1678.3 (3700)    |
| 1321-3TH880-BB | NJ6            | 460            | 460             | 1                 | 1678.3 (3700)  |                  |

1321-Mxxx Common Mode Chokes

1321-Mxxx Common Mode Chokes can be installed with the following Allen-Bradley AC drives.

- PowerFlex® 4-Class
- PowerFlex 520-Series
- PowerFlex 7-Class
- PowerFlex 750-Series
- 1305
- 1336 PLUS™
- 1336 PLUS™ II
- 1336 IMPACT™
- 1336 FORCE™

When installed at the drive output the common mode choke helps to guard against interference with other electrical equipment (Programmable Controllers, sensors, analog circuits, and so forth). In addition, reducing the PWM carrier frequency reduces the effects and lowers the risk of common mode noise interference.

Catalog Number Explanation

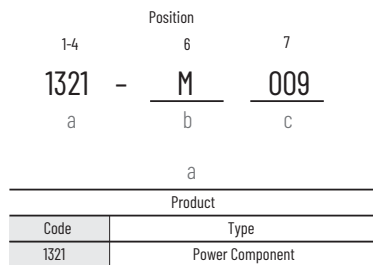

\* Same core as 1321-M009. Can be used in place of the M009, M048, or M180 if the terminal block and windings typical of those ratings are not desired.

## Ratings

### PowerFlex AC Drives

| Choke Type                              | Used With             | Ratings   | Catalog Number |
|---|-----------------------|---|----------------|
| Open Style, 1A                          | All PowerFlex Drives  | Communication Cables, Analog Signal Cables, and so forth  | 1321-M001      |
| Open Style, 9A<br>(with terminal strip) | PowerFlex 4M/4/40/40P | 0.2...1.1 kW (0.25...2 HP), 100...115V<br>0.2...1.5 kW (0.25...2 HP), 200...240V<br>0.4...2.2 kW (0.5...3 HP), 380...480V   | 1321-M009      |
|   | PowerFlex 400         | 2.2 kW (3 HP) 400...480V  |                |
|   | PowerFlex 520-Series  | 0.2...1.1 kW (0.25...1.5 HP), 100...120V<br>0.2...1.1 kW (0.25...2 HP), 208...240V<br>0.4...2.2 kW (0.5...3 HP), 400...480V |                |
|   | PowerFlex 7-Class     | 0.3...2.2 kW (0.5...3 HP), 208...230V<br>0.4...4 kW (0.5...5 HP), 400...480V  |                |
|   | PowerFlex 750-Series  | 0.75...4 kW (0.5...5 HP), 400...480V  |                |
| Open Style, 48A                         | PowerFlex 4M/4/40/40P | 2.2...7.5 kW (3...10 HP), 200...240V<br>2.2...11 kW (3...15 HP), 380...480V<br>2.2...11 kW (3...15 HP), 600V                | 1321-M048      |
|   | PowerFlex 400         | 2.2...11 kW (3...15 HP), 200...240V<br>4...22 kW (5...30 HP), 380...480V  |                |
|   | PowerFlex 520-Series  | 0.2...14 kW (3...20 HP), 200...240V<br>4...22 kW (5...30 HP), 400...480V<br>5.5...22 kW (7.5...30 HP), 600V                 |                |
|   | PowerFlex 7-Class     | 2.2...11 kW (3...15 HP), 208...240V<br>4...22 kW (5...30 HP), 400...480V<br>5.5...37 kW (10...40 HP), 600V                  |                |
|   | PowerFlex 750-Series  | 5.5...22 kW (7.5...30 HP), 400...480V<br>5.5...37 kW (7.5...40 HP), 600...690V  |                |
| Open Style, 55A                         | PowerFlex 7-Class     | 14 kW (20 HP), 208...240V<br>22...30 kW (30...40 HP), 400...480V<br>45 kW (50 HP), 600V                                     | 1321-M055      |
|   | PowerFlex 750-Series  | 22...30 kW (30...40 HP), 400...480V<br>45 kW (50 HP), 600...690V  |                |
| Open Style, 180A                        | PowerFlex 7-Class     | 14...44 kW (20...60 HP), 208...240V<br>30...110 kW (40...150 HP), 400...480V<br>45...132 kW (50...150 HP), 600V             | 1321-M180      |
|   | PowerFlex 750-Series  | 30...90 kW (40...125 HP), 400...480V<br>45...132 kW (50...150 HP), 600...690V   |                |
| Open Style, 670A                        | PowerFlex 7-Class     | 55...75 kW (75...100 HP), 208...240V<br>149...373 kW (200...500 HP), 400...480V<br>149...522 kW (200...700 HP), 600V        | 1321-M670      |
|   | PowerFlex 750-Series  | 110...447 kW (150...600 HP), 400...480V<br>149...597 kW (200...800 HP), 600...690V  |                |

### Allen-Bradley Legacy AC Drives

| Choke Type                              | Used With                         | Ratings  | Catalog Number |
|---|-----------------------------------|--|----------------|
| Open Style, 1A                          | All Legacy Drives                 | Communication Cables, Analog Signal Cables, and so forth             | 1321-M001      |
| Open Style, 9A<br>(with terminal strip) | 1305, 1336 PLUS, and 1336 PLUS II | 0.37...2.2 kW (0.5...2 HP), 230V<br>0.37...3.7 kW (0.5...5 HP), 480V | 1321-M009      |
|   | 1336 IMPACT                       | 0.37...3.7 kW (0.5...5 HP), 480V                                     |                |
|   | 1336 FORCE                        | 0.75 kW (1 HP), 230V<br>0.75...2.2 kW (1...3 HP), 480V and 600V      |                |

## Allen-Bradley Legacy AC Drives (Continued)

| Choke Type       | Used With                  | Ratings  | Catalog Number |
|------------------|----------------------------|--|----------------|
| Open Style, 48A  | 1336 PLUS and 1336 PLUS II | 2.2...11 kW (3...15 HP), 230V<br>5.5...22 kW (7.5...30 HP), 480V<br>0.75...30 kW (1...40 HP), 600V       | 1321-M048      |
|                  | 1336 IMPACT                | 5.5...22 kW (7.5...30 HP), 480V<br>5.5...30 kW (7.5...40 HP), 600V                                       |                |
|                  | 1336 FORCE                 | 2.2...11 kW (3...15 HP), 230V<br>2.2...22 kW (3...30 HP), 480V<br>0.75...30 kW (1...40 HP), 600V         |                |
| Open Style, 55A  | 1336 PLUS II               | 14 kW (20 HP), 230V<br>22...30 kW (30...40 HP), 480V<br>45 kW (50 HP), 600V                              | 1321-M055      |
|                  | 1336 IMPACT                | 22...30 kW (30...40 HP), 480V<br>45 kW (50 HP), 600V   |                |
| Open Style, 180A | 1336 PLUS and 1336 PLUS II | 15...45 kW (20...60 HP), 230V<br>30...112 kW (40...150 HP), 480V<br>37...112 kW (50...150 HP), 600V      | 1321-M180      |
|                  | 1336 IMPACT                | 30...112 kW (40...150 HP), 480V<br>37...93 kW (50...125 HP), 600V  |                |
|                  | 1336 FORCE                 | 15...45 kW (20...60 HP), 230V<br>30...112 kW (40...150 HP), 480V<br>37...112 kW (50...150 HP), 600V      |                |
| Open Style, 670A | 1336 PLUS and 1336 PLUS II | 56...93 kW (75...125 HP), 230V<br>112...448 kW (150...600 HP), 480V<br>149...448 kW (200...600 HP), 600V | 1321-M670      |
|                  | 1336 IMPACT                | 112...448 kW (150...600 HP), 480V<br>149...448 kW (200...600 HP), 600V                                   |                |
|                  | 1336 FORCE                 | 56...93 kW (75...125 HP), 230V<br>112...448 kW (150...600 HP), 480V<br>149...448 kW (200...600 HP), 600V |                |

## Approximate Mounting Dimensions

1321-M001 Choke Assembly

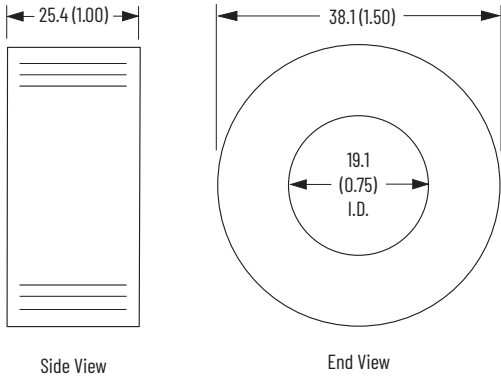

Dimensions in mm (inches)

1321-M009 Choke Assembly

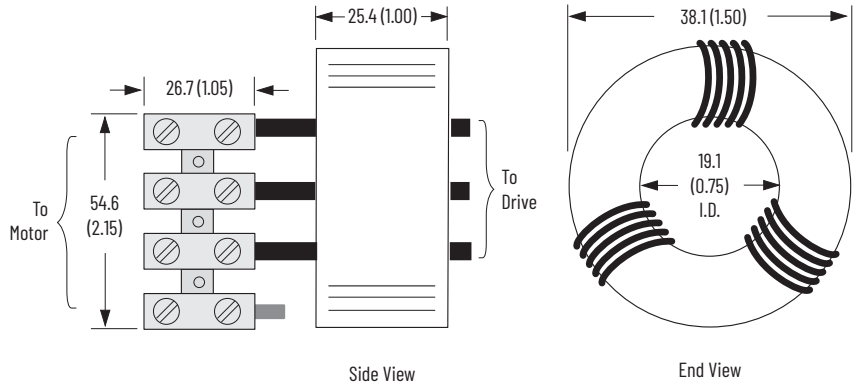

Dimensions in inches (mm)

1321-M048 Choke Assembly

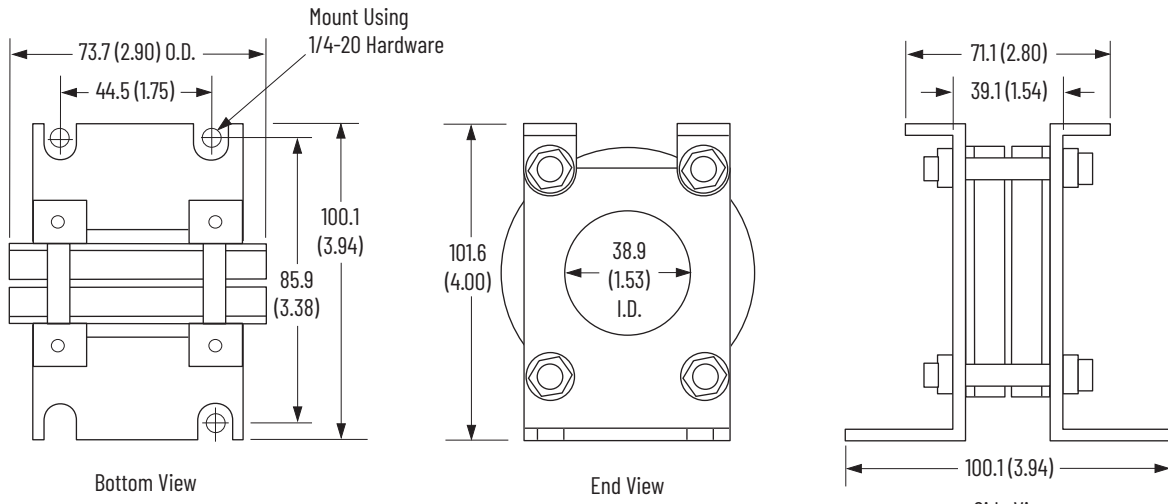

Dimensions are in mm (in.)

1321-M055 Choke Assembly

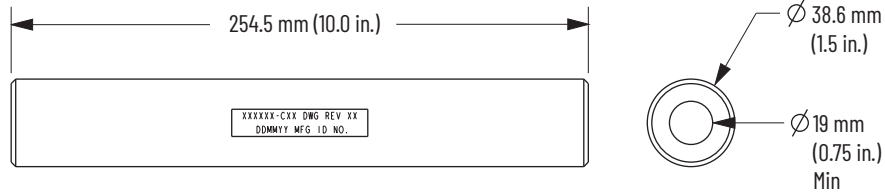

Dimensions in mm (inches)

## 1321-M180 Choke Assembly

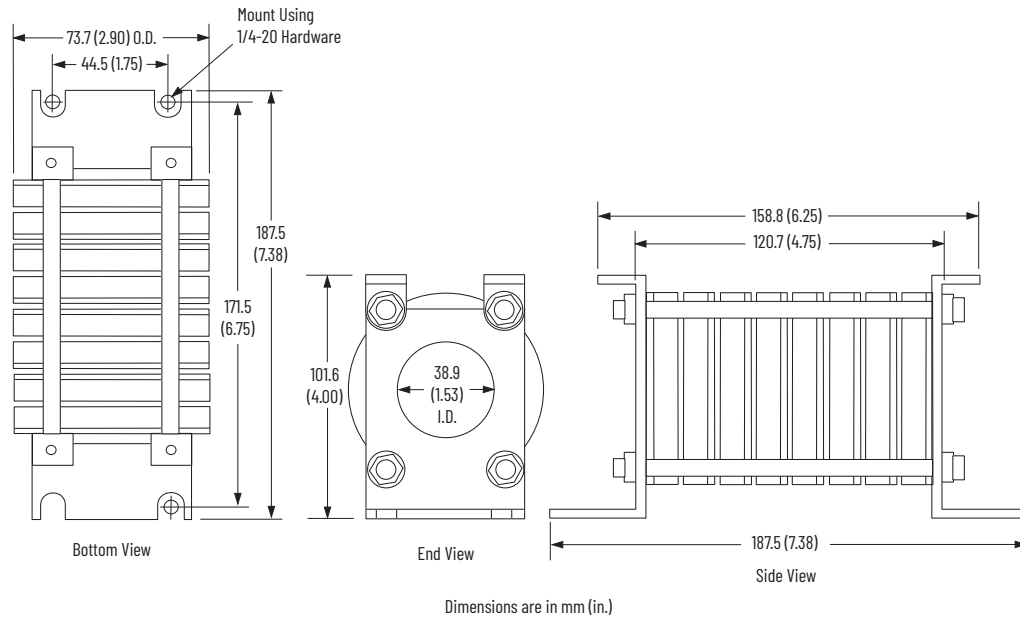

## 1321-M670 Choke Assembly

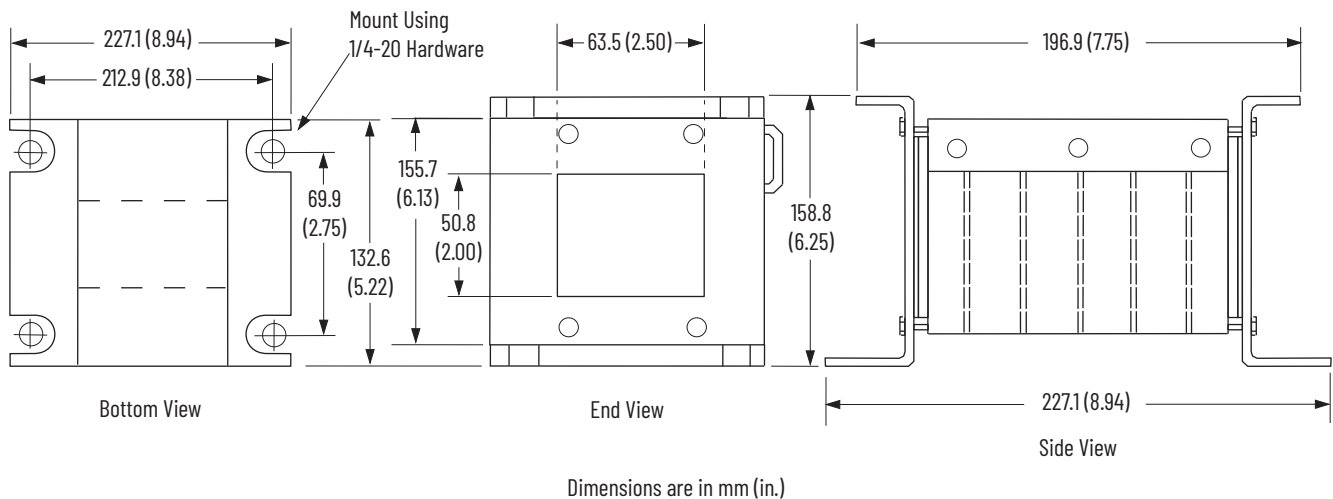

## 1321-DC DC Link Chokes

1321-DC DC Link Chokes can be installed with Frame C PowerFlex 40 and all PowerFlex 400 drives. Add DC Link Chokes in series with the internal DC Bus to:

- Reduce AC input line harmonics
- Help meet IEEE-519 limits
- Absorb voltage/current spikes
- Reduce AC ripple on DC bus
- Reduce dv/dt and di/dt rates
- Solve spurious overvoltage tripping
- Reduce DC bus transient overvoltage

## Catalog Number Explanation

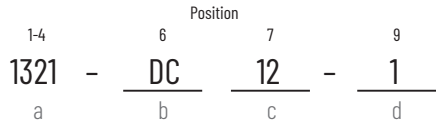

| a       |                 |
|---------|-----------------|
| Product |                 |
| Code    | Type            |
| 1321    | Power Component |

| b      |               |
|--------|---------------|
| Device |               |
| Code   | Description   |
| DC     | DC Link Choke |

| c              |      |
|----------------|------|
| Current Rating |      |
| Code           | Amps |
| 9              | 9    |
| 12             | 12   |
| 18             | 18   |
| 25             | 25   |
| 32             | 32   |
| 40             | 40   |

| d                 |   |
|-------------------|---|
| Inductance Rating |   |
| Code              | Description   |
| 1                 | Each DC Link Choke current rating may have more than one inductance rating. Refer to Ratings for specific values. |
| 2                 |   |
| 3                 |   |
| 4                 |   |

## Specifications

| Specification                    | Rating   |
|----------------------------------|--|
| General                          | UL-508 component that is recognized (File E196302) |
|                                  | 1000 Volts DC maximum                              |
|                                  | For ripple frequency of 300 Hz or 360 Hz           |
|                                  | 50 °C temperature rise                             |
|                                  | Suitable for 40 °C ambient temperature             |
|                                  | Class B insulation system (130 °C)                 |
|                                  | Suitable for ripple current of 10% peak-to-peak    |
|                                  | Touch-safe terminals in many ratings               |
| Storage Temperature (all const.) | -40...+70°C (-40...+158°F)                         |
| Humidity                         | 5...95% noncondensing                              |

## Special Features

- Solid copper box lug type terminals on most sizes
- Specially constructed and epoxy impregnated for low noise
- Customized ratings also available - contact the factory for custom mounting, inductance, current or ripple requirements

## Ratings

| Catalog Number | Type       | DC Amps | mH   | Watts | Lug Size | Torque N-m (lb-in) |
|----------------|------------|---------|------|-------|----------|--------------------|
| 1321-DC9-2     | Open Style | 9       | 3.22 | 7     | 22-14    | 4.5 (39.8)         |
| 1321-DC12-1    | Open Style | 12      | 1    | 5     | 22-14    | 4.5 (39.8)         |
| 1321-DC12-2    | Open Style | 12      | 2.1  | 7     | 18-4     | 20 (177.02)        |
| 1321-DC18-1    | Open Style | 18      | 0.65 | 5     | 18-4     | 20 (177.02)        |
| 1321-DC18-4    | Open Style | 18      | 3.75 | 17    | 18-4     | 20 (177.02)        |
| 1321-DC25-4    | Open Style | 25      | 1.75 | 13    | 18-4     | 20 (177.02)        |
| 1321-DC32-1    | Open Style | 32      | 0.85 | 11    | 18-4     | 20 (177.02)        |
| 1321-DC32-2    | Open Style | 32      | 1.62 | 14    | 18-4     | 20 (177.02)        |
| 1321-DC32-3    | Open Style | 32      | 2.68 | 21    | 18-4     | 20 (177.02)        |
| 1321-DC40-2    | Open Style | 40      | 0.75 | 15    | 18-4     | 20 (177.02)        |
| 1321-DC40-4    | Open Style | 40      | 2    | 29    | 18-4     | 20 (177.02)        |

## Approximate Mounting Dimensions

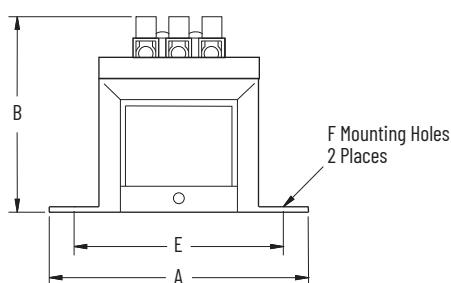

Figure 1

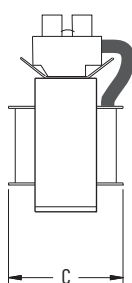

Figure 2

| Catalog Number | Figure | Dimensions in mm (in.) |              |              |             |              |                           |
|----------------|--------|------------------------|--------------|--------------|-------------|--------------|---------------------------|
|                |        | A                      | B            | C            | D           | E            | F                         |
| 1321-DC9-2     | 1      | 95.3 (3.75)            | 82.6 (3.25)  | 50.8 (2)     | (-)         | 79.5 (3.13)  | 47.5 DIA. (0.187 DIA.)    |
| 1321-DC12-1    | 1      | 95.3 (3.75)            | 82.6 (3.25)  | 44.5 (1.75)  | (-)         | 79.5 (3.13)  | 47.5 DIA. (0.187 DIA.)    |
| 1321-DC12-2    | 2      | 96.8 (3.81)            | 114.3 (4.5)  | 71.6 (2.82)  | 50.8 (2)    | 79.5 (3.13)  | 5.2 x 8.3 (0.203 x 0.328) |
| 1321-DC18-1    | 1      | 95.3 (3.75)            | 82.6 (3.25)  | 50.8 (2)     | (-)         | 79.5 (3.13)  | 47.5 DIA. (0.187 DIA.)    |
| 1321-DC18-4    | 2      | 117.6 (4.63)           | 133.4 (5.25) | 101.6 (4)    | 63.5 (2.5)  | 95.3 (3.75)  | 5.2 x 8.3 (0.203 x 0.328) |
| 1321-DC25-4    | 2      | 96.8 (3.81)            | 114.3 (4.5)  | 76.2 (3)     | 63.5 (2.5)  | 79.5 (3.13)  | 5.2 x 8.3 (0.203 x 0.328) |
| 1321-DC32-1    | 2      | 96.8 (3.81)            | 114.3 (4.5)  | 84.3 (3.32)  | 63.5 (2.5)  | 79.5 (3.13)  | 5.2 x 8.3 (0.203 x 0.328) |
| 1321-DC32-2    | 2      | 117.6 (4.63)           | 133.4 (5.25) | 108.0 (4.25) | 76.2 (3)    | 95.3 (3.75)  | 5.2 x 8.3 (0.203 x 0.328) |
| 1321-DC32-3    | 2      | 117.6 (4.63)           | 133.4 (5.25) | 133.4 (5.25) | 101.6 (4)   | 95.3 (3.75)  | 5.2 x 8.3 (0.203 x 0.328) |
| 1321-DC40-2    | 2      | 96.8 (3.81)            | 114.3 (4.5)  | 95.3 (3.75)  | 76.2 (3)    | 79.5 (3.13)  | 5.2 x 8.3 (0.203 x 0.328) |
| 1321-DC40-4    | 2      | 165.1 (6.5)            | 166.4 (6.55) | 152.4 (6)    | 85.9 (3.38) | 134.9 (5.31) | 7.1 x 13.2 (0.28 x 0.52)  |

**Notes:**

## Additional Resources

These documents contain additional information concerning related products from Rockwell Automation.

| Resource   | Description   |
|--|---|
| Wiring and Grounding Guidelines for Pulse Width Modulated (PWM) AC Drives, publication <a href="#">DRIVES-IN001</a>                | Basic information that is needed to properly wire and ground PWM AC drives.   |
| American Standards, Configurations, and Ratings: Introduction to Motor Circuit Design, publication <a href="#">IC-AT001</a>        | Provides an overview of American motor circuit design based on methods that are outlined in the NEC.  |
| Industrial Components Preventive Maintenance, Enclosures, and Contact Ratings Specifications, publication <a href="#">IC-TD002</a> | Provides a quick reference tool for Allen-Bradley industrial automation controls and assemblies.  |
| Safety Guidelines for the Application, Installation, and Maintenance of Solid-state Control, publication <a href="#">SGI-1.1</a>   | Designed to harmonize with NEMA Standards Publication No. ICS 1.1-1987 and provides general guidelines for the application, installation, and maintenance of solid-state control in the form of individual devices or packaged assemblies incorporating solid-state components. |
| Industrial Automation Wiring and Grounding Guidelines, publication <a href="#">1770-4.1</a>  | Provides general guidelines for installing a Rockwell Automation industrial system.   |
| Product Certifications website, <a href="http://rok.auto/certifications">rok.auto/certifications</a> .                             | Provides declarations of conformity, certificates, and other certification details.   |

You can view or download publications at [rok.auto/literature](http://rok.auto/literature).

# Rockwell Automation Support

Use these resources to access support information.

|   |  |  |
|---|--|--|
| <b>Technical Support Center</b>                         | Find help with how-to videos, FAQs, chat, user forums, and product notification updates.           | <a href="http://rok.auto/support">rok.auto/support</a>             |
| <b>Knowledgebase</b>                                    | Access Knowledgebase articles.   | <a href="http://rok.auto/knowledgebase">rok.auto/knowledgebase</a> |
| <b>Local Technical Support Phone Numbers</b>            | Locate the telephone number for your country.  | <a href="http://rok.auto/phonesupport">rok.auto/phonesupport</a>   |
| <b>Literature Library</b>                               | Find installation instructions, manuals, brochures, and technical data publications.               | <a href="http://rok.auto/literature">rok.auto/literature</a>       |
| <b>Product Compatibility and Download Center (PCDC)</b> | Download firmware, associated files (such as AOP, EDS, and DTM), and access product release notes. | <a href="http://rok.auto/pcdc">rok.auto/pcdc</a>                   |

## Documentation Feedback

Your comments help us serve your documentation needs better. If you have any suggestions on how to improve our content, complete the form at [rok.auto/docfeedback](http://rok.auto/docfeedback).

Allen-Bradley, expanding human possibility, PowerFlex, and Rockwell Automation are trademarks of Rockwell Automation, Inc. Trademarks not belonging to Rockwell Automation are property of their respective companies.

Rockwell Automation maintains current product environmental compliance information on its website at [rok.auto/pec](http://rok.auto/pec).

Rockwell Otomasyon Ticaret A.Ş. Kar Plaza İş Merkezi E Blok Kat:6 34752, İçerenköy, İstanbul, Tel: +90 (216) 5698400 EEE Yönetmeliğine Uygundur

Connect with us.    

[rockwellautomation.com](http://rockwellautomation.com)

expanding human possibility®

AMERICAS: Rockwell Automation, 1201 South Second Street, Milwaukee, WI 53204-2496 USA, Tel: (1) 414.382.2000

EUROPE/MIDDLE EAST/AFRICA: Rockwell Automation NV, Pegasus Park, De Kleetlaan 12a, 1831 Diegem, Belgium, Tel: (32) 2663 0600

ASIA PACIFIC: Rockwell Automation SEA Pte Ltd, 2 Corporation Road, #04-05, Main Lobby, Corporation Place, Singapore 618494, Tel: (65) 6510 6608

UNITED KINGDOM: Rockwell Automation Ltd., Pitfield, Kiln Farm, Milton Keynes, MK11 3DR, United Kingdom, Tel: (44)(1908) 838-800

Publication 1321-TD001T-EN-P - July 2024

Supersedes Publication 1321-TD001S-EN-P - October 2022

Copyright © 2024 Rockwell Automation, Inc. All rights reserved. Printed in the U.S.A.